

S T R O M B E R G
ARCHITECTURAL PRODUCTS

Glass Fiber Reinforced Concrete (GFRC)
Glass Fiber Reinforced Polymer (GFRP)



Glossary of Architectural Terms

4400 ONEAL STREET • GREENVILLE, TX 75401

P: 903.454.0904 • F: 903.454.0233

WWW.4STROMBERG.COM • SALES@4STROMBERG.COM

GFRC | GFRP | GFRG | CAST STONE | MARBLE | BRONZE

Abacus

The abacus is the top part of a column capital. Abacus may be a square slab or a molded shape. In GFRC (glass fiber reinforced concrete) or Architectural Fiberglass column capitals, the abacus may be cast as part of the capital or as a separate piece. Latin: "abacus" = table, tablet.

Found in classical Greek and Roman architecture and derivatives, including Beaux Arts Classicism, Classical Revival, Federal, Georgian Revival, Greek Revival, Neoclassicism, Renaissance Revival, Second Empire, Gothic and Gothic Revival. Abacus may be cast stone, FRP (Architectural Fiberglass,) GFRC (glass fiber reinforced concrete,) GRG (glass fiber reinforced gypsum,) plaster, bronze, granite or marble.



Abacus of a Roman Ionic Column Capital cast in GFRC

Abated

In stone cutting, hammered metal work, and the like, cut away or beaten down, lowered in any way, as the background of a piece of ornament or a bas relief panel, so as to show a pattern or figure in relief. Abated work may be cast stone, FRP (architectural fiberglass,) GFRC (glass fiber reinforced concrete,) GRG (glass fiber reinforced gypsum,) plaster, bronze, granite or marble.

Abrasive Finish

A flat and grainy surface texture. In cast stone, GFRC (glass fiber reinforced concrete) or architectural precast concrete this is accomplished by acid washing or sand blasting. In GFRP (architectural fiberglass) or GFRC (glass fiber reinforced gypsum,) plaster or bronze, this is accomplished either in the mold, or with sandblasting. With granite or marble this is accomplished with sandblasting.

Abrasive Hardness

A measure of the wearing qualities of marble, granite, GFRC, architectural fiberglass or other materials. Mostly applies when those materials are used for floors, stair treads, and other areas subjected to abrasion by foot traffic. Refer to ASTM C241.

Abut

To touch, or join at its end; as in a beam where the end is planted against another member of a structure, but without trim around it; or where a GFRC arch bears upon a pier, course of stone, skew back, or the like.

Acanthus

A can thus. Acanthus leaves are the stylized leaves of the acanthus plant, used in decoration on column capitals of the Corinthian and Composite orders. Because of the deep undercuts, special rubber molds are used when casting them in GFRC (glass fiber reinforced concrete,) architectural fiberglass, GFRG or Cast Stone.



Drawing of an Acanthus Leaf

Corinthian column capital in architectural fiberglass (GFRP) featuring stylized Acanthus leaves.



Accouplement

The placing of two columns or pilasters very close together. This pairing is common and is most effective when several pairs of columns are used in series to form a colonnade.



Italian Ionic GFRC columns used in accouplement

Accolade

An ornamental treatment of the archivolt or hood molding of an arch or of the moldings of an apparent arch, or of a form resembling an arch, as in late Gothic work.

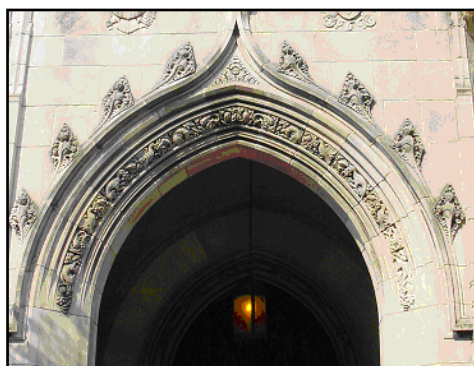

Accolade in architectural fiberglass (GFRP)



Accolade in architectural fiberglass (GFRP)

Acorn

An ornament in the shape of an acorn sometimes used as a pendant or decorative element. In GFRC (glass fiber reinforced concrete) and GFRP (architectural fiberglass) acorn finials are generally cast with a dowel or threaded insert for attaching them to the substrate.

Acoustics

Acoustics is the science concerned with the production, control, transmission, reception, and the effects of sound. The term refers to the natural laws governing sound and the design of structures to utilize sound in the best way. These laws are similar in many ways to those for the reflection and refraction of light. Architectural acoustics with interior GFRC or GFRG panels is primarily applicable to the design of opera houses, concert halls, churches and other religious meeting spaces, convention centers, hotels and similar facilities. GFRC and GFRG panels can be curved and shaped to reflect sound in the desired direction. Both GFRC and GFRG can be textured in various degrees to reflect, diffuse and absorb sound as may be required. The weight per square foot of GFRC and GFRG can be varied depending on the desires of the acoustical consultant. For a good example of acoustic panels see the Ave Maria page.

External links for more information:

Acoustical Society of America

<http://asa.aip.org/>

American Institute of Architects

<http://www.aia.org/>

(continued on next page)

National Council of Acoustical Consultants

<http://www.ncac.com/>

Acroterion or Acroterium

From the Greek word "acroterion" - the summit or extremity. An ornamented pedestal at the corner or peak of a roof. Acroterion may be a palmate, a statue or a pedestal. GFRC, glass fiber reinforced concrete, may be used for new acroterion, or GFRC, glass fiber reinforced concrete, may be used as replacement for stone or terra-cotta acroterion. Attachment in GFRC or GFRP (architectural fiberglass) is through metal straps that attach to the roof.



Acroterion by Stromberg

Adam Style

A style which developed in the late 18th century, from the work of Robert Adam and his brothers. Adam was born in Scotland and educated at the University of Edinburgh. Robert Adam was the architect to the king, until 1768, when he was succeeded by his brother James. The Adam style strongly influenced the American colonies and is the basis of the Federal style. The Adam style is noted for its elegance and lightness, subtle detailing and unified schemes of interior design, including fan ornaments, festoons, wreaths, urns, ribbons, and classical elements. Both GFRC (glass fiber reinforced concrete) and GFRP (glass fiber reinforced plastic or architectural fiberglass) is uniquely suited to the replication of Adam style ornamentation. Adam style GFRC, columns, capitals, fireplace mantles, balustrade, ceilings, garden urns and planters, etc.



Adam Style Fireplace Mantel in GFRC

Aggregate

A granular, inert material, such as sand, crushed limestone, marble, etc. which is mixed with Portland cement, glass fibers, and polymers to create GFRC, glass fiber reinforced concrete. The type of aggregate used helps determine the color, texture and durability of the GFRC. In architectural fiberglass (GFRP) aggregate may be used for a stone like surface gel coat.



Close up of acid etched GFRC showing the grains of fine aggregate in the cement matrix.

American Institute of Architects (AIA)

An organization founded in 1857 for the purpose of promoting the professionalism and accountability of its members, and a devotion to design excellence. AIA, 1735 New York Avenue NW, Washington, DC 20006. American Institute of Architects <http://www.aia.org/>

American Society of Landscape Architects (ASLA)

Founded in 1899, is the professional organization of landscape architects in America. ASLA 4401 Connecticut Ave. NW, Washington, DC 20008

American Society for Testing Materials (ASTM)

Establishes test standards for materials and products in the United States, including those used in building construction. ASTM 1916 Race Street, Philadelphia PA 19103

Anchor

A fastener used to secure GFRC (glass fiber reinforced concrete) or GFRP (architectural fiberglass) to a structure. Anchor types for GFRC include dowels, weld plates, straps, dovetails, threaded inserts, screws and Z clips. When metal frames are used with GFRC, glass fiber reinforced concrete, flex anchors are bent metal rods, used to connect the GFRC face, to a metal frame. The flex anchors, which are typically stainless steel or galvanized steel, allow for variations in thermal expansion and contraction, between the GFRC and the steel frame. The anchor must carry gravity loads, wind loads, seismic loads, etc and transfer them from the GFRC (glass fiber reinforced concrete) to the structure.

GFRC anchors • Some types of GFRC and cast stone anchors are illustrated below:

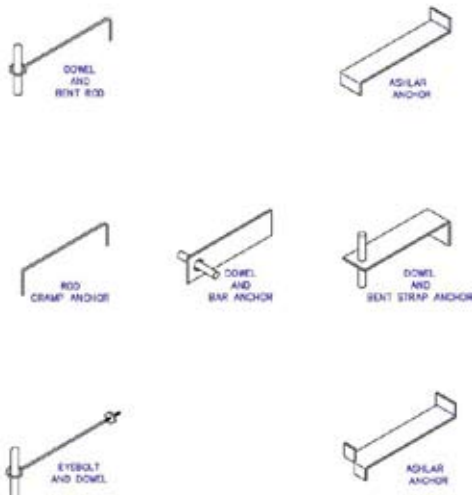

Stone type anchors for GFRC veneer

Anchors for GFRC can be designed to anchor the individual element or to attach the GFRC to a light gauge metal frame which is in turn anchored to the wall.

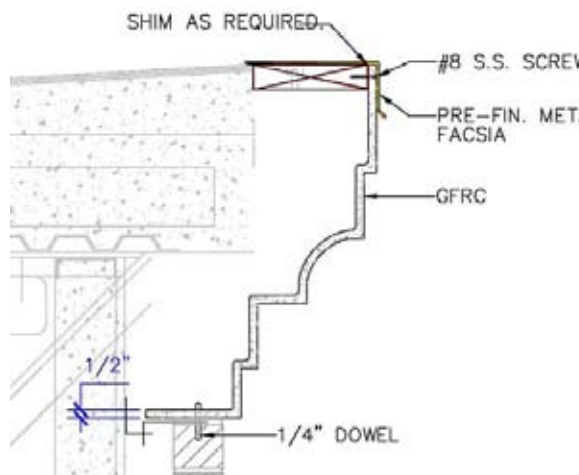

Screw anchor attachment of GFRC cornice

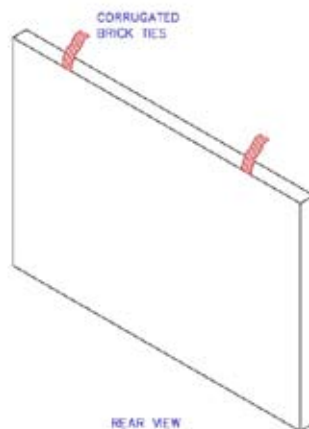

Cast in anchor straps for GFRC panels

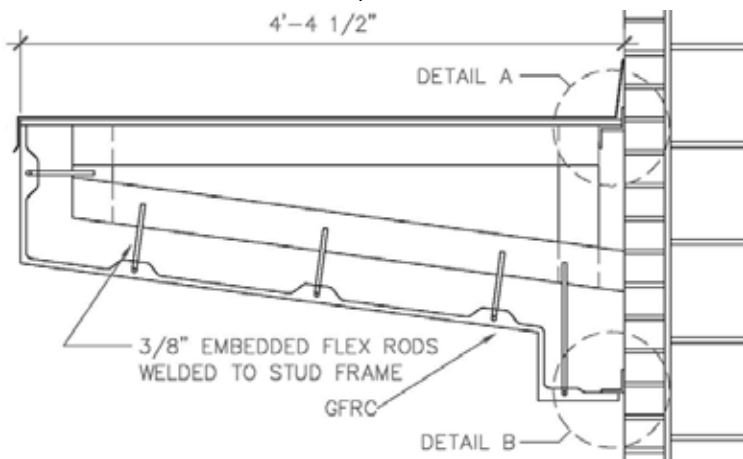

Flex anchors on metal stud frame for GFRC panels and cornice

View of a GFRC cornice showing the use of galvanized metal stud framing and stainless steel flex anchors.



Anchors for architectural fiberglass are similar to GFRC anchors. Anchors for architectural fiberglass include cast in straps, screws, threaded inserts, light gauge metal frames and tube steel frames, stainless steel dowels, wedge anchors and bolts.

Ancon

From the Greek: "ancone" - elbow or hollow. A decorative or scroll bracket that supports a cornice or entablature over a mantle, door or window. Both architectural fiberglass (GFRP) and GFRC, glass fiber reinforced concrete, ancons, are lighter and easier to install than traditional carved stone or terracotta.



Ancon (a console or scroll shaped bracket)

Angle Capital

With Ionic capitals, a special angle capital is sometimes used for the column on the outside corners. The four volutes project equally on a diagonal toward the corner. With GFRC, glass fiber reinforced concrete, angle capitals are not always available in standard molds, and if desired must be special ordered.

Angular Pediment

Also known as a triangular pediment. The pediment having slanting sides and a horizontal cornice. In GFRC (glass fiber reinforced concrete) large angular pediments are cast in segments. Small angular pediments may be made as one-piece GFRC units.



*Angular Pediment in GFRC by Stromberg
Examples of Angular*



*Pediments at Caesars, Las Vegas
Angular Pediment in GFRC by Stromberg*



Antebellum

Antebellum architecture refers to structures that existed before the United States Civil War. GFRC (glass fiber reinforced concrete) and Architectural Fiberglass by Stromberg have been used in the restoration of several antebellum structures.

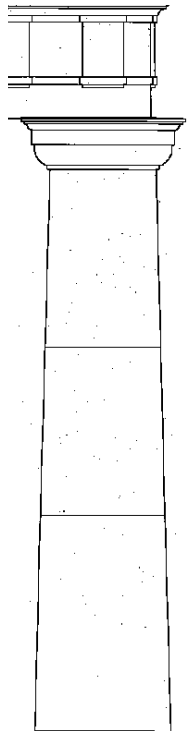

Example of Antebellum style of column and entablature, cast in GFRC for Antebellum architecture.



Antebellum style columns and trim for the University of Virginia.

Antefix

A decorated upright ornament at the eaves or at the peak of a triangular gable.



Anthemion

A commonly used Greek decoration shaped like a palm leaf. They are used singly or as a running ornament. Also referred to as honeysuckle ornament. Found on moldings, cornices, pediments and bands. Also found on the necking of some Ionic capitals.

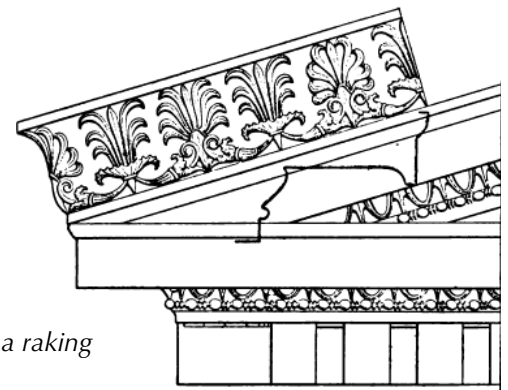

Anthemion design on a raking cornice.

Appliqué

An ornamented work applied to a structure. GFRC (glass fiber reinforced concrete) and Architectural Fiberglass (GFRP) appliqués may be attached by dowels and epoxy or by specialty clip hangers.

Apse

A nearly semicircular part of a building, the interior forming a large niche.



Apse in GFRC

Aquarium

A tank or vessel for filled with water for keeping live fish or other water dwelling creatures.



Stromberg architectural fiberglass and GFRS aquarium backs at Atlantis

Arbor

An open structure of supports and beams, usually supporting vines or flowers. GFRC (glass fiber reinforced concrete) and GFRP (architectural fiberglass) arbors offer the advantage of being relatively light, weather resistant, and durable. The word arbor comes from the French herbere, which originally meant a place to grow herbs. An arbor defines a space and has an open-work roof for shade or capable of being used for supporting plants. Arbors are of three main varieties: The true arbor, the pergola (a colonnade with a flat roof) and the gallery (a tunnel like arbor with an arched roof).



Tuscan columned Arbor / Pergola



Arbor / Pergola at Atlantis Bahamas Custom columns. Beams are cast in wood timber texture in architectural fiberglass. This arbor / pergola has stood up to the tropical sun and 2 hurricanes.

Areostyle

Term in classical column architecture for having columns separated by a clear space of four or more column diameters. See Intercolumniation.

Arcade

Two or more arches, usually a entire series of arches, with their columns, impost, piers, pilasters or the like taken together and considered a single architectural feature.

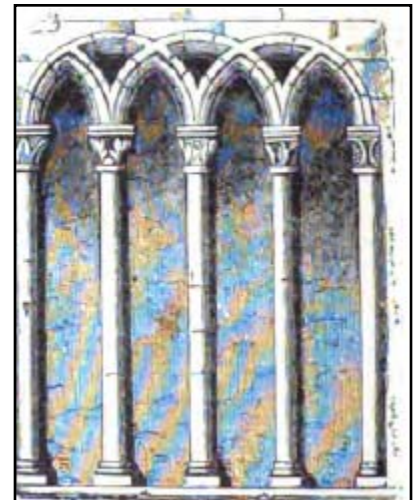

Historic Example of Intersecting Arcade

Arch

The shape that spans an opening, usually curved. If it is made wedge-shaped blocks, these blocks are called voussoirs. There are all types of arches, from those with little or no curve to pointed arches. GFRC (glass fiber reinforced concrete) and GFRP (architectural fiberglass) may be used in arch cladding, wrapping a structural member, to provide the appearance of the arch. Occasionally, the GFRC (glass fiber reinforced concrete) actually functions as an arch to support the GFRC above it.

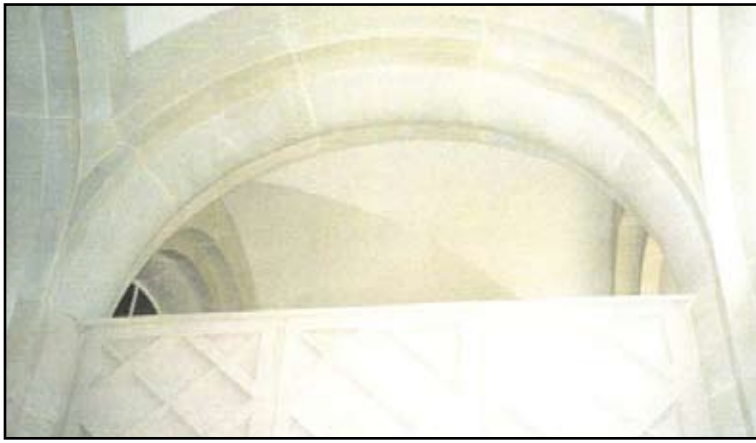

Arch at the Mansion residences, Dallas.

Types of Arches

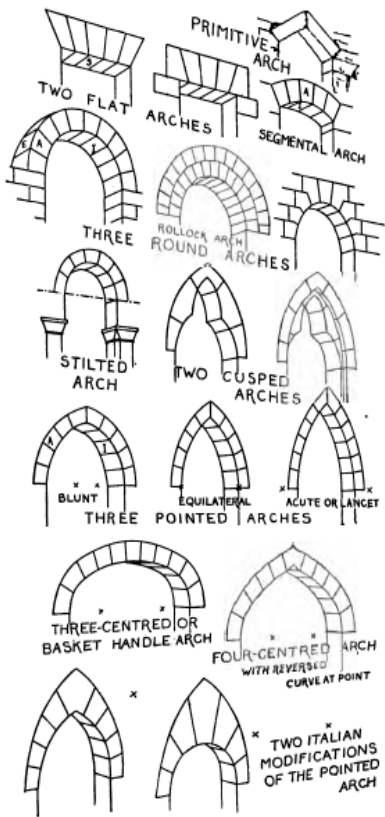

Cast arches by Stromberg in architectural fiberglass (GFRP)



Arch cast in Stromberg architectural fiberglass

Architectural Terra-cotta

A glazed burnt Clay architectural unit. Terra-cotta was used as a facing on buildings in America mostly from around 1860 until the 1930s. In historic restorations, because of difficulties in replacing terra-cotta, color matching and durability issues, GFRC (glass fiber and first concrete) is often used as the terra-cotta replacement. Stromberg produces a special glazed GFRC which closely resembles glazed terra-cotta. Custom color matching is available, and new GFRC can be created with molds taken from existing terra-cotta, or from historic drawings and photographs if the terra-cotta no longer exists. When properly performed, GFRC or FRP replacements of terra-cotta should be virtually indistinguishable from the original material. GFRC (glass fiber reinforced concrete) offers great benefits in replacing glazed architectural terra-cotta.

Benefits of GFRC:

- Anchoring provisions are included in the GFRC casting.
- Color compatible.
- Non combustible material, GFRC will not burn.
- Light weight.
- Durable and long lasting
- Suitable for seismic zones.
- Fast production times.

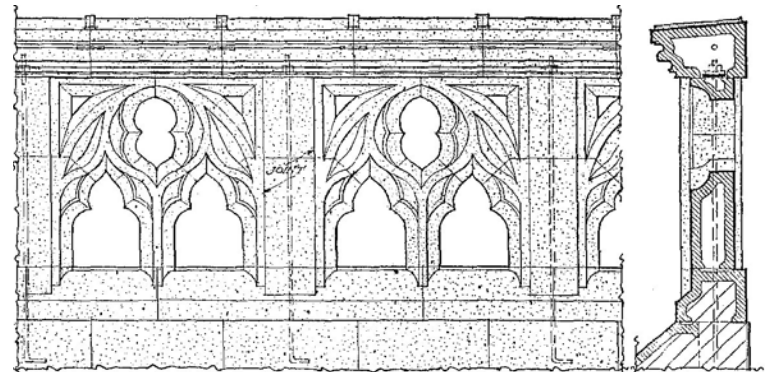

Top: Architectural terra-cotta railing replaced with GFRC.

Arched Dormer

A dormer with an arched roof. Often found in the Beaux Arts Style, French Style or Second Empire Style, etc GFRC (glass fiber reinforced concrete) and GFRP (architectural fiberglass) dormers may be one-piece units, or the dormer face only.

Architectural Style

A way of classifying buildings that share common attributes. Architectural styles are often related to a particular period of time, country of origin or region.

Right: New Corinthian column capital as a terra-cotta replacement.



Architrave

An ornamental molding or band above or around a door or window opening. In the classical orders, the architrave was the lowest member of the entablature or beam that spans from column to column. GFRC (glass fiber reinforced concrete) and GFRP (architectural fiberglass) architraves are typically U shaped beam wraps.

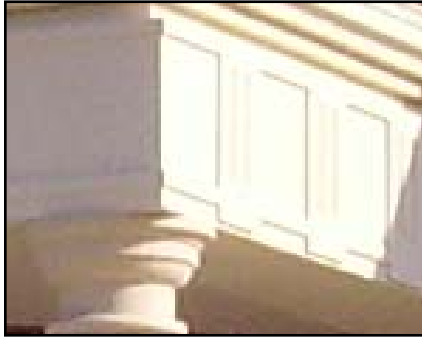

GFRC Architrave

Archivolt

The inner most part of the arch.

Arch Stone

A wedge-shaped GFRC, Architectural Fiberglass, or masonry unit in an arch. Sometimes called a voussoir.



Arch stone or voussoir in GFRC



Carved voussoirs or arch stones. Cast by Stromberg in a custom color and texture architectural fiberglass.



Arris

The external angle intersection between two flat or curved faces, as between two flutes of a column, or the flat raised area between the columns concave flutes.

Arris on an architectural fiberglass (GFRP) Corinthian column

Art Deco

A decorative style characterized by angular, ribbon, zigzag or other geometric ornamentation in low relief on buildings facades. Became popular in American architecture in the 1930's. GFRC (glass fiber reinforced concrete) and GFRP (architectural fiberglass) Art Deco elements include moldings, columns, domes, fireplaces, windows surrounds, entryways, medallions, finials, ceilings and others. Art Deco is sometimes referred to as "Style Moderne".



Column element in the art deco style (Hollywood Casino)



Art deco medallion / ceiling in architectural fiberglass by Stromberg.



Art Deco slab edge molding



Bas relief architectural fiberglass panels

Art Nouveau

A style of architectural and applied art characterized by organic forms, curving designs and dynamic shapes. Similar in many ways to the foliage motifs used by the American architect Louis Sullivan. GFRC (glass fiber reinforced concrete) and GFRP (architectural fiberglass) Art Nouveau elements include statuary, moldings, medallions, fireplace surrounds and fireplace mantels, planters, bas relief, door and window surrounds, panels, domes and ceilings.

Ashlar

Is the term for rectilinear, squared-off blocks of stone used in building. GFRC (glass fiber reinforced concrete) and GFRP (architectural fiberglass) are produced in various ashlar types. The GFRC and Architectural Fiberglass ashlar may be individual blocks, but is often large panels with scored "false joints" and interlocking joints.

**Types of Ashlar include:**

- Ashlar rock-faced: A block whose face has been roughly hacked.
- Ashlar masonry: Smooth rectangular stones laid in horizontal courses.
- Coursed ashlar: Ashlar masonry built of stones having the same height within each course, but each course varying in height from the others.
- Random ashlar: Ashlar masonry where the stones appear to be laid without a specific pattern, although the pattern may be repeated.



Ashlar panels, Stromberg GFRS (glass fiber reinforced stone) a type of architectural fiberglass, Atlantis, Bahamas.



Panels in ashlar pattern

Astragal

A half round shape, with the fillet on one or both sides. An example is the neck molding at the top of a column shaft directly below the capital.



Astragal on a GFRC column capital



Atlantes

A human figure, that acts as a pier, column or pilaster supporting an entablature. Found in Greek architecture. Female figures are Caryatid, male figures are Atlantes.

Atlas or Atlante in GFRC (glass fiber reinforced concrete) for use as a pier, column, fireplace mantel support or pilaster.

Atlas

The singular form of Atlantes.

Attic Base

A column base with two rings (An upper and lower torus). Attic bases are most often used with Corinthian columns, composite columns and Ionic columns.

Tuscan columns have a single ring at the column base and Doric columns (if they have a base) use a single ring or torus.

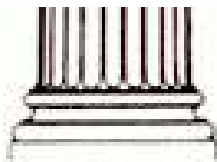

Axed work

A "stone type" surface which shows tool marks from a bush hammer, ax or pick. In GFRC (glass fiber reinforced concrete) axed work is produced by casting against a custom made mold. May be used on panels, quoins and other Architectural Fiberglass elements where a more rustic texture is desired.

Back hearth

Is the part of the hearth within the fireplace. For wood-burning fireplaces, GFRC (glass fiber reinforced concrete) fireplace hearths typically end with the front hearth, and the back hearth is made from firebrick.

Balconet

Is a false balcony, in front of a window. GFRC (glass fiber reinforced concrete) and GFRP (architectural fiberglass) Balconets may include support brackets and balustrade. Balconets are typically cast with either threaded rod or a Z clip type fastener and are bolted on or clipped to the structure.



Door surround / entry with a false balcony or balconet.

Balcony

A platform projecting out from a building, enclosed with a railing or balustrade. GFRC (glass fiber reinforced concrete) and GFRP (architectural fiberglass) Balcony components include brackets, balustrade, face molding and soffit. Columns and pilasters may be incorporated into the balcony design. Because

it's lightweight, GFRC and Architectural Fiberglass can give the look and feel of stone, without it adding an excessive amount of weight to the balcony.



Balcony with GFRC balustrade, brackets or corbels, and balcony trim.



Balcony with curved front and balustrade balcony railings. Architectural fiberglass by Stromberg.



Balcony at Shalimar (private residence) California



Balcony with cast arch and balustrade



Corinthian columns and balustrade (style G29) cast in a white limestone color and texture. Balusters are hollow and are attached to the structure with threaded rods.

Balcony Railing

The railing around a balcony. In GFRC and Architectural Fiberglass, it may be a balustrade or a solid railing. It is important that the building codes be followed in any balcony railing installation. In most areas, these require a 42" height to the top of the railing and a railing that a 4" ball cannot pass through. With Architectural Fiberglass and GFRC balustrade, there are various ways of meeting these requirements. The balusters are typically attached to the structure with threaded rods. For drainage, baluster rails may be elevated above the balcony to allow water to flow under the balustrade, or scuppers can be incorporated into the base rail of the balustrade. Alternately, balusters may be used with no base rail and the water is allowed to drain off between the GFRC or Architectural Fiberglass balusters.



Balcony railing for a hotel and resort. This balustrade railing was delivered and installed in full sections. The ends have clips for attachment to the structure. This balustrade / railing meets all the code requirements for height, spacing and strength. Water drainage for the balustrade is accomplished with the raised bottom rail. Material is Stromberg architectural fiberglass.



Balcony Railing in a Gothic tracery rather than a balustrade

Ball Flower

A round ornament found in Gothic architecture resembling a flower.

Baluster

One of the short, vertical support members of a balustrade. Balusters of GFRC (glass fiber reinforced concrete) and GFRP (architectural fiberglass) offer a relatively light, durable balustrade. In areas where the balustrade protects from a fall off, such as on the balcony, code requires minimum spacing of the balusters. The word **baluster** (sometimes called banister or bannister) is derived from the Italian balaustro which means

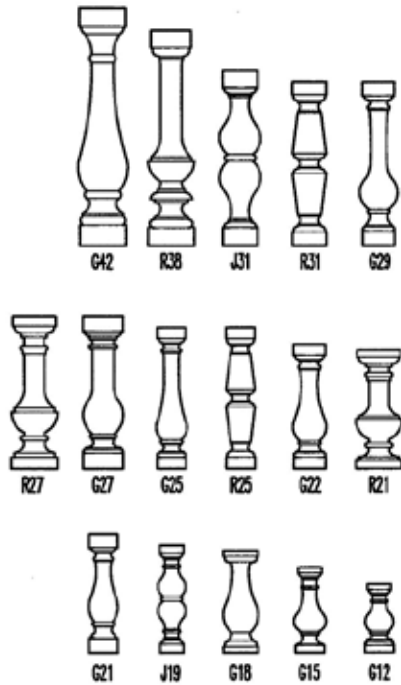

“pomegranate flower” from its resemblance to the flowers vase like shape. (The French balustre, in Italian balaustro, Latin balaustum, and Greek balaustion.) The baluster dates back to ancient Assyria where it was used in windows. Balusters and balustrade was used in several renaissance palaces and balconies in Venice and Verona. Architect Giuliano da Sangallo used the baluster on the terrace at the villa at Poggio a Caiano around 1480. Donato Bramante used balustrade on his famous building the Tempietto in 1502, which set the style of high renaissance architecture. Famed sculptor, painter and architect Michelangelo is reported to have

designed the first simple vase shaped baluster and used balustrade on several of his works. Balusters and balustrade can be found in almost all architectural styles.



Balustrade with rough travertine texture • Cast in architectural fiberglass

Balustrade

The complete railing system consisting of the Baluster, top rail and sometimes bottom rail. Balustrade is typically used at the edge of a patio, porch, balcony or roof. Several styles of balustrade are available in GFRC (glass fiber reinforced concrete) as well as GFRP (architectural fiberglass).

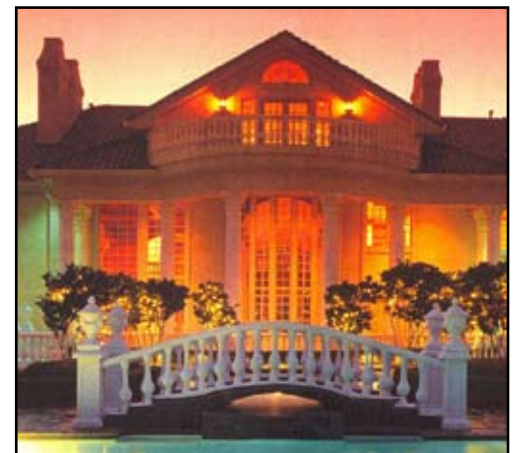
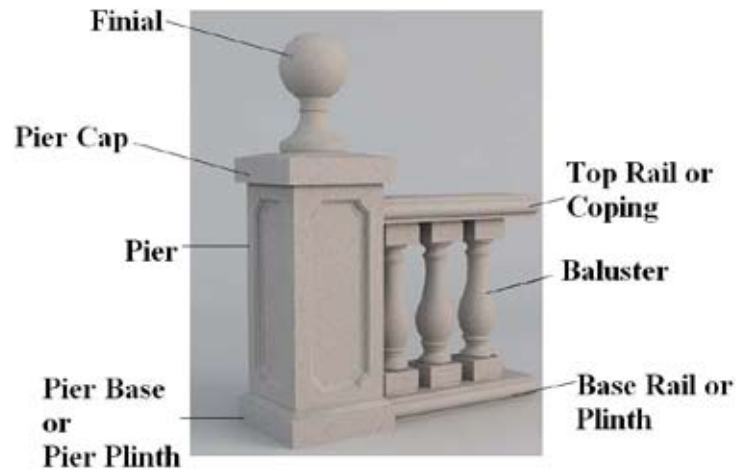

Balustrade at private residence



Balustrade as bridge railing



Balustrade as parapet wall • Architectural Fiberglass (GFRP)



Balustrade at fountain • Style G29 baluster and style W10 baluster railing • Cast stone



Band or band molding. The horizontal molding, projecting from the surface that wraps around a building. Also known as a belt course or watertable.



Cast stone

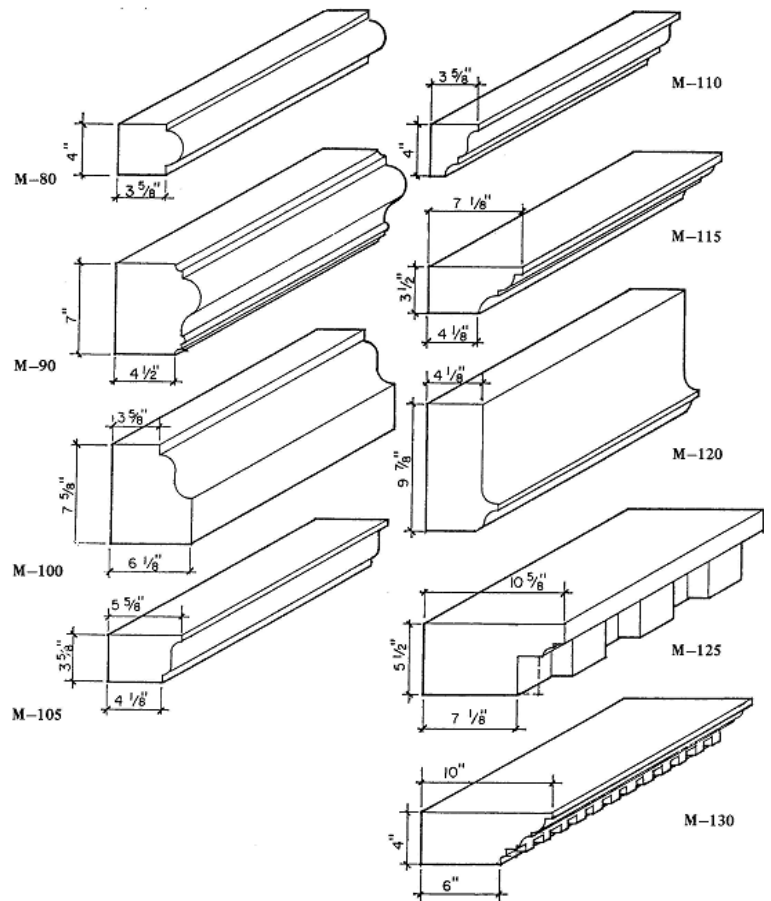

Band molding M80

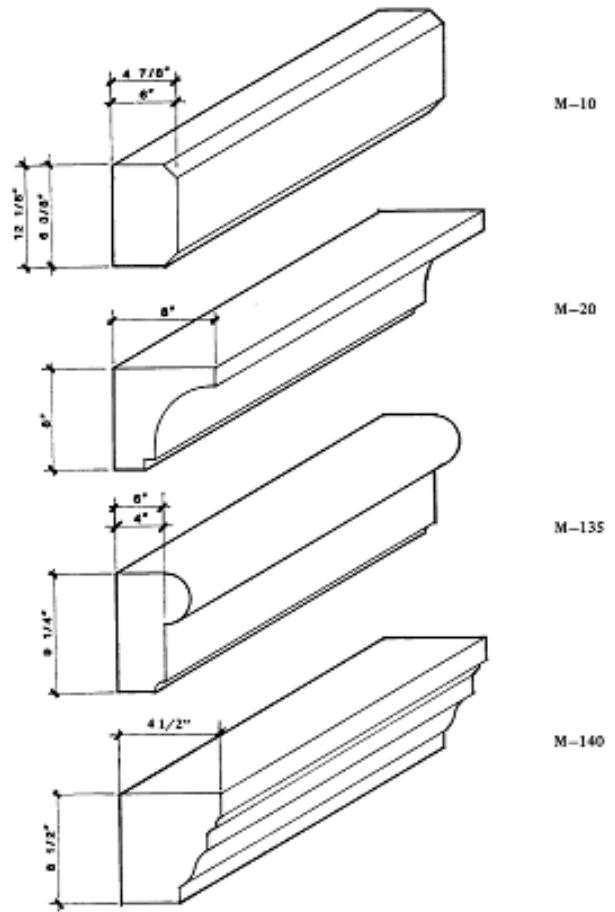
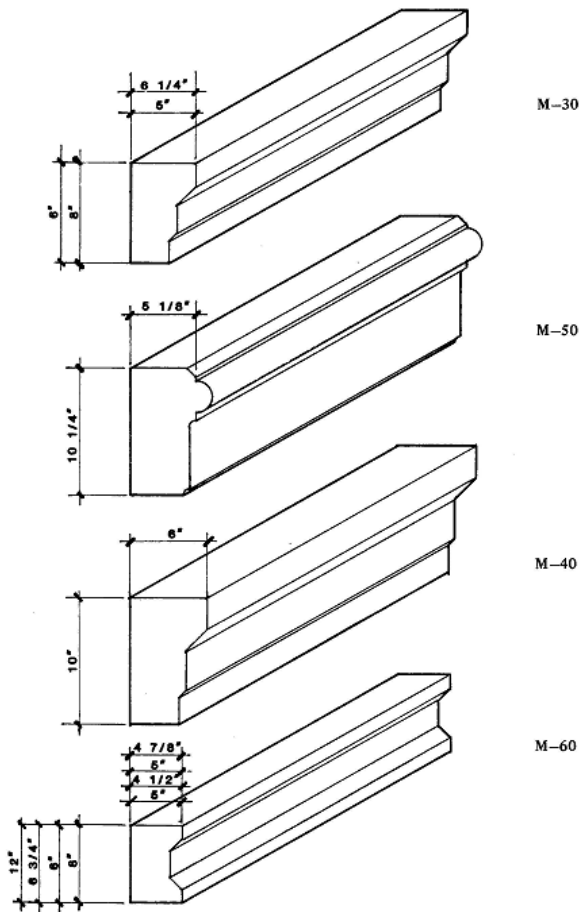

Some of the standard belt courses and band moldings. Custom shapes and sizes are available in both GFRC and Architectural Fiberglass.

Banded

Masonry style where adjacent courses are of two different sizes, textures or types. For example, a brown, smooth Architectural Fiberglass, alternating with a white limestone Architectural Fiberglass.

Banded Column

A column where the column shaft has drums that alternate in texture or size.

Baroque

The style of architecture and decoration first developed in 17th-century Italy. Characterized by the conspicuous use of decoration, sculpture and decorative elements. Elements from the later phases of the Baroque, called for Rococo are characterized by profuse ornamentation. Elements of the Baroque are found in the late 19th century work of American architects McKim, Mead and White.

Barrel Roof

An arched, semi-cylindrical roof. Barrel roof in GFRC (glass fiber reinforced concrete) and GFRP (architectural fiberglass) are generally made in segments, withstanding standing seam joints and raised ribs.



Barrel Vault

A semi-cylindrical, arched ceiling element. GFRP (architectural fiberglass) barrel vaults may be smooth or coffered.

Base

The lower part of a column, pier, pedestal or pilaster. Column bases may be either Attic column bases or Tuscan.

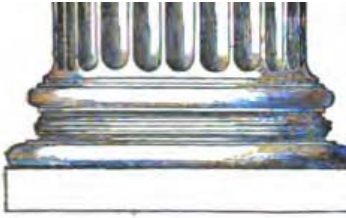

Attic column base features double rings found on the Corinthian order.

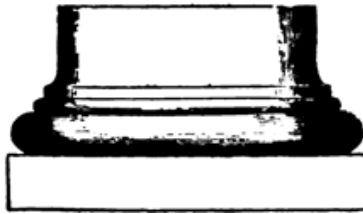

Base for a Tuscan column

Bas-Relief

A sculpted or carved work that extends slightly from the plane of its background. GFRC (glass fiber reinforced concrete) and GFRP (architectural fiberglass) bas-reliefs, include plaques, monuments and medallions. What is believed to be the largest GFRC bas-relief sculpture in the world, was created by Stromberg in 2006. For the reproduction of bas-relief in glass fiber reinforced concrete, a model is produced in clay, wood or plaster. A mold is then made using silicone rubber and a hard shell of fiberglass. Once the mold is removed from the model, the GFRC is cast. Depending on the size of the glass fiber reinforced concrete bas relief, a metal armature on the interior, generally galvanized or stainless steel, may be cast in. The casting is then sand blasted or acid washed to remove the cement film from the surface of the glass fiber reinforced concrete and to obtain the desired finish.

Battlement

Originally a fortification, a parapet or wall with higher and lower parts. The higher part is the Merlon, the lower the Crenelle or Crenel. The Raised part or Merlon was often pierced by a hole to allow for firing an arrow. The design was adopted for decoration and can be found on many older garden walls and eventually became a decorative element.

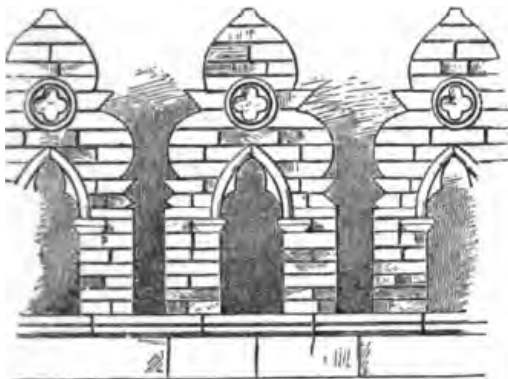

Battlement in Garden wall, Venice



Stromberg architectural fiberglass battlements, castle at Winstar

Battered

A term used to describe a surface that is inclined or tilted, wider at the bottom and narrower at the top, for example a battered wall.

Bead

A convex molding of semicircular section.

Beam

The term for a horizontal member, when used in Architectural Fiberglass or GFRP typically refers to a beam cover. Architectural Fiberglass beams may replicate stone or wood.



Architectural fiberglass "wood beam" by Stromberg

Beaux Arts Architecture

Architecture taught at and associated with, the Ecole des Beaux Arts. Characterized by formalism in design, heavily rusticated arches, mansard roofs, (continued on next page)

Beaux Arts Architecture - continued

Symmetrical plans, sculpted figures, banded columns, arched dormers, cartouches, cantons, floral patterns, ornamented keystones, quoins, engaged columns, paired columns, roof line balustrades and garlands. American architects who graduated from the Ecole, include Richard Morris Hunt, designer of the Breakers, William Ware, Charles McKim, Louis Sullivan and Julia Morgan. Facades are typically symmetrical, often with a projecting central pavilion. GFRC (glass fiber reinforced concrete) and GFRP (architectural fiberglass) architectural elements are available in the Beaux Arts style including dentils, classical columns, enriched entablatures, pilasters, balconies, cornices, sculpted spandrels, pilasters, balconies, cornices, sculpted spandrels, sculpted figures, ornamental keystones, egg and dart moldings, leaf decorations, swags, wreaths, domes, fireplace surrounds and mantles, quoins, cartouches, dormers, fountains, domes, etc.

Bed Molding

A molding or moldings on the cornice of an entablature, below the corona.

**Belfry**

The part of a tower or steeple where bells are hung. Also called a bell tower.

The Bell Tower of "Big Ben" in architectural fiberglass by Stromberg with 120' tall with working clocks.

Bell Roof

A roof or dome shaped in section similar to a bell. In GFRC (glass fiber reinforced concrete) and GFRP (architectural fiberglass) typically cast in pie shape sections, and assembled on-site.

Bell Tower

Tower like structure for supporting one or more bells. Can contain real bells or play recorded music.

Belt Course

Horizontal band around the facade of the building, also called a band course or string course.

Belvedere

An elevated or rooftop gazebo or pavilion from which to enjoy a view.



*Belvedere pergola
GFRC and architectural
fiberglass*

Bevel

Also known as a chamfer, bevels are sometimes incorporated in the edges of architectural GFRC (glass fiber reinforced concrete) and GFRP (architectural fiberglass) to minimize chipping of sharp 90° corners.

Bollard

A short freestanding column designed to limit vehicle traffic or act as security.



GFRC Bollards at the US Capital

Bracket

A support that carries or appears to carry the weight of the cornice, eave or balcony. In GFRC (glass fiber reinforced concrete) (continued on next page)



Bracket - continued

and GFRP (architectural fiberglass) brackets are typically decorative covers, and do not actually carry any weight.

Bracketed Cornice

Any cornice, supported by brackets. In GFRC (glass fiber enforced concrete) and GFRP (architectural fiberglass) brackets may be molded into the cornice, or applied as separate pieces.



Bracketed trim in architectural fiberglass

Bracketed Hood

A projecting element above a door or window that provides shelter from the rain, and is supported by brackets.

Brick Panels

GFRP (architectural fiberglass) cast in panels with a brick texture and pattern, and used instead of brick. Architectural Fiberglass brick panels are lighter, thinner, and faster to install than traditional brick masonry.



Architectural fiberglass brick panels, Hershey's Times Square, New York

Broach

A spire, octagonal in shape, above a square tower.

Broken Pediment

A pediment whose horizontal cornice is continuous, but whose angled cornice above ends before reaching the highest point of the pediment. The resulting opening is often filled with an urn or finial. Often found in Georgian style, Queen Anne Style, Colonial Revival, and Neoclassical Style buildings.

Brownstone

A reddish or brown sandstone used extensively for buildings in the eastern United States from the early 19th century through the 1920's. Stromberg GFRC (glass fiber reinforced concrete) and GFRP (architectural fiberglass) using pigments and select aggregates can replicate the color and texture of Brownstone.

Building Restoration

The re-creating of the form and details of a building, as it appeared at a particular time. GFRC (glass fiber reinforced concrete) is an accepted material of replacement for terra-cotta, carved stone, cut stone, brownstone and some cast iron elements.



BEFORE RESTORATION



AFTER RESTORATION

Building Stone

Stone used in building construction such as limestone, marble, granite or sandstone. Building Stone may be used as a facing on GFRP (architectural fiberglass) panels, or GFRC (glass fiber enforced concrete) can be cast with building Stone aggregates to replicate the look and appearance of cut stone.

Bull's-eye Window

A round window, surrounded by decorative molding often found in gables or pediments. Also called an oculus, oeil de boeuf, or ox eye window.

Camber Window

Window that has a slight arch at the top.

Campanario

Spanish word for bell tower.

**Canale**

In Spanish Colonial architecture, a waterspout used to direct rainwater through the face of the parapet and away from the walls. In modern times, canale made from GFRP (architectural fiberglass,) may be functional or merely decorative.

Decorative stylized canale in architectural fiberglass (GFRP,) Florida

Canton

An outside corner of a building, decorated with a projecting masonry course, pilasters or similar elements.

Capital

The uppermost element of a column or plaster. GFRC (glass fiber reinforced concrete) and GFRP (architectural fiberglass) column capitals are available as Corinthian, Ionic, Doric, Tuscan, Scammozzi, Composite and temple of the winds as well as custom shapes.

Cartouche

An ornamented tablet or shield often framed by elaborate carving.



Cartouche in GFRC (also available in architectural fiberglass, cast stone, GFRC, GFRS)

Cast Iron Architecture

Ornamental cast iron that replicated stone columns and beams that was popular in many American cities especially New York, St. Louis, and New Orleans. The cast iron architecture was characterized by the use of repetitive modules. Many cast iron facades were created in the Italianate Style and Second Empire style. No longer readily available in cast iron, missing components of the structures are effectively replaced with GFRC (glass fiber reinforced concrete) and GFRP (architectural fiberglass). Molds for the GFRC (glass fiber reinforced concrete) and GFRP (architectural fiberglass) may be taken from existing elements, or re-created from historic drawings or photographs.

Cavetto

A round concave molding or cornice continuing at least a quarter circle.

Ceiling Dome

A dome used for the interior ceiling. May be part of a double dome system with interior and exterior domes.

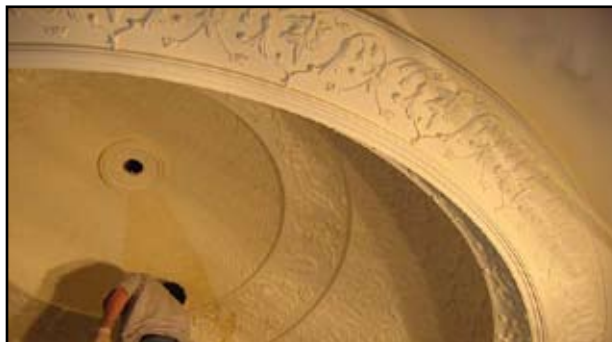

Ornamented ceiling dome being installed (GFRC)

Ceiling Medallion

An ornament for the ceiling, generally round, oval or hexagonal shape.



Architectural fiberglass ceiling medallion in art deco style

Cement

Made from heated limestone and shale, Portland cement when combined with aggregate, glass fibers and polymers is cast to create GFRC (glass fiber reinforced concrete).

Chateau Style

Also known as Chateausque style. A style of architecture based on the monumental French Chateau's of the 16th century. Chateau style was introduced in America by Richard Morris Hunt. GFRP (architectural fiberglass) and GFRC (glass fiber reinforced concrete) architectural elements that are available in the Chateau style include limestone facade, pilasters, pinnacles, dormers, finials, gables, balustrade, built courses, gargoyles, griffins, roof cresting, pedimented parapets, corner turrets, decorative chimneys, ornamental chimney caps, hood moldings, fireplace mantles, etc.

Chimney

The vertical structure that contains one or more flues and carries of smoke and combustion products from a fireplace. Chimneys can be important design elements, and the use GFRC (glass fiber reinforced concrete) chimney covers with a brick, Fieldstone, carved stone or other texture allows for light weight, weather resistant and noncombustible alternative to traditional chimney construction.

Chimney Cap

A cornice or coping that crowns the top of the chimney. GFRC (glass fiber reinforced concrete) chimney caps are noncombustible and protect masonry chimneys from rain and whether. GFRC chimney caps may have a molded profile, and a texture of sandstone, limestone, coral stone or other material.

**Chimney Hood**

Noncombustible covering that protects the opening at the top of the chimney from snow and rain but allows smoke to escape. GFRC (glass fiber reinforced concrete) is non combustible, weather resistant and relatively light and so an excellent choice for a chimney top.

Chimney Pot

A round decorative shape on top of the chimney, used to increase its height and as a decorative element. Custom GFRC (glass fiber reinforced concrete) chimney pots are available in a range of styles and sizes, generally used with a cast stone or terra-cotta color. Since GFRC is non combustible and relatively light, it is a safe and intelligent material to use in this application.

Cinquefoil

A pattern having five lobes divided like cusps, found in windows in the Gothic revival style.

**Circular Window**

A window having the shape of a full circle. Often with keystones set at four points, in a radial manner.

Cladding

The exterior covering of a building. GFRP (architectural fiberglass) and GFRC (glass fiber reinforced concrete) cladding may be supplied with a metal framework behind the cladding, or as individual panels.

Classical Revival Style

Style architecture typified by simplicity dignity and purity of design sometimes referred to as Jeffersonian classicism, because it is often associated with the work of Thomas Jefferson. Examples include Jefferson's home at Monticello, the University of Virginia, and the Virginia State Capitol. It was later revived with some modifications and referred to as the neoclassical style. GFRP (architectural fiberglass) elements that are available in the classical revival style include triangular pediments, columns in the Doric or Tuscan order, Roman Ionic and Corinthian orders. Dentils, triglyphs, fireplace surrounds, door surrounds, moldings, cornice, mantles and balustrade.

Clock Tower

A tower for a clock. May feature chimes.

Architectural fiberglass clock tower with working clocks and chimes

**Coffer**

Recessed panels in the ceiling, arch or dome; they may be square or octagonal and sometimes are highly ornamented. GFRC (glass fiber reinforced concrete) or GFRP (architectural fiberglass) coffers are used for exterior applications or GFRG for interiors.



GFRG Ceiling Coffers



Coffers of GFRG

Column

In classical architecture consists of the capital the shaft and a base shaft may be either monolithic (one piece,) built up of a number of cylinders, or may be split vertically, to wrap a structural column. GFRC (glass fiber reinforced concrete) columns have a typical average wall thickness of between 1/2" and 1".

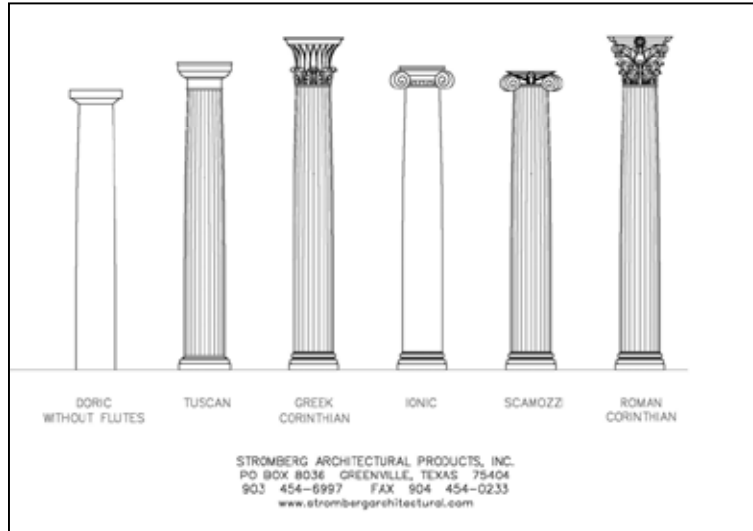

Composite Capital

A Roman modification of the Corinthian capital has volutes similar to an Ionic capital. Since the composite capital is less widely used than the other orders, it is available in only a few stock sizes in GFRP (architectural fiberglass,) and is generally a custom piece.

Composite Order Diagram

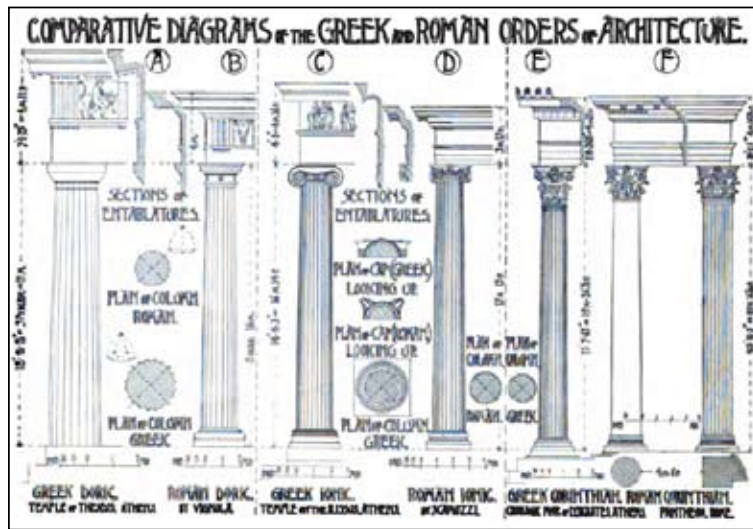

Composite Order

The Composite Order developed late in the Roman period as modified version of the Corinthian Order.

The acanthus leaves of the normal Corinthian capital were combined with the volutes of the Ionic Order. The other details of the columns and the entablature resemble those of the Corinthian Order. While the Ionic and Corinthian Orders are two of the three Greek Orders of Architecture, the Composite order was not used by the Greeks. The composite order is less widely used than other orders and is available in fewer stock sizes in GFRP (architectural fiberglass,) but can be custom fabricated.

Concrete Matrix

The concrete portion of GFRC (glass fiber reinforced concrete,) which is formed by mixing an aggregate, such as crushed stone or sand, with Portland cement, polymers and water.

Console

A bracket, in the form of the scroll which projects from a wall and supports a door head, cornice, fireplace mantel, shelf, etc. also known as an ancon. GFRC (glass fiber reinforced concrete) and GFRP (architectural fiberglass) corbels and brackets may be modified and used as consoles.



Coquina

A limestone formed from prehistoric shells and coral. Coquina stone was used in the construction of Spanish colonial dwellings in early Florida. GFRC (glass fiber reinforced concrete) with Coquina stone texture and feel, is produced using a special manufactured mold, produced from quarried Coquina stone, and a specially designed GFRC mixture. Coquina stone columns, piers and trim are available as well as coquina window and door surrounds and other architectural components in GFRC. Coquina stone GFRC is available in a range of mottled pastel colors. Because the areas where coquina stone was once quarried are now either developed or in environmentally sensitive locations, GFRC cast coquina is an environmentally
(continued on next page)

Coquina - continued

superior solution. The coquina texture is also available in panels, brackets, keystones, etc in GFRP (architectural fiberglass).

Coral Stone

A sedimentary limestone, formed from fossilized coral and seashells. Coral stone was widely used in construction of many of the great mansions in southern Florida, and was popularized by architects such as Addison Mizner. Coral Stone GFRP (architectural fiberglass) is available in a range of pastel colors and white. GFRP coral stone is stronger than quarried coral stone and architectural fiberglass is readily available and is more environmentally friendly. GFRP (architectural fiberglass) cast with coral stone texture, provides a material which is virtually indistinguishable from quarried coral stone. Coral stone ashlar, coral stone columns, coral stone brackets, coral stone piers, balusters, trim, wall cap and other coral stone shapes are all available in Architectural Fiberglass.



Coral stone trim in GFRC

Fossil Stone texture similar to coral stone but with a heavier texture and more fossils.



Corbel

A projecting bracket, often decorated, designed to support an architectural element above it. A variety of stock mold GFRC (glass fiber reinforced concrete) and GFRP (architectural fiberglass) corbels and brackets are available.



Corbels supporting a cornice

Corinthian Capital

The capital for the Corinthian column. A series of acanthus leaves, surrounding a central bell.

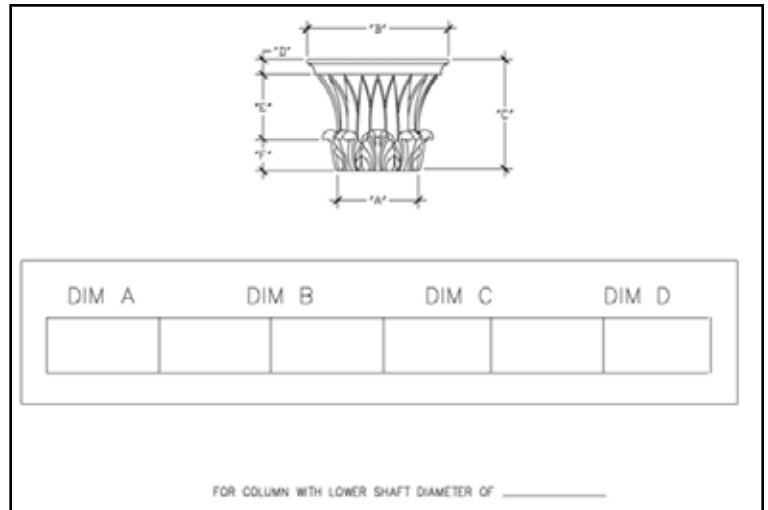

Corinthian Order

One of the three classical orders of architecture. While the Corinthian order takes its name from the city of Corinth in Greece. It actually seems to have been developed in Athens during the fifth century BC. The leaves surrounding the capital represent stylized acanthus leaves. The legend of its origin is that a sculptor, visiting the grave of a young girl, found an urn filled with her possessions, on top of her grave, covered with a square tile on top to protect the contents. An acanthus plant had grown around the urn, curling over at the corners of the tile. Moved and inspired by the sight, he created a column capital in the shape of a round urn encircled with acanthus leaves. The details of the Corinthian column base, shaft and entablature are similar to the

(continued on next page)

Corinthian Order - continued

Ionic order. GFRC (glass fiber reinforced concrete) and GFRP (architectural fiberglass) Corinthian columns are available as standard mold items, and even-numbered diameters (10 inch, 12 inch, 14 inch, etc.) GFRC (glass fiber and first concrete) and GFRP (architectural fiberglass) Corinthian pilasters are available in the same sizes. As a loose rule of thumb, Corinthian columns are typically 8 to 12 diameters in height, for example a 1 foot diameter (measured lower shaft) column would be eight to 12 feet tall, and a 2 foot diameter column would be 16 to 24 feet in height.

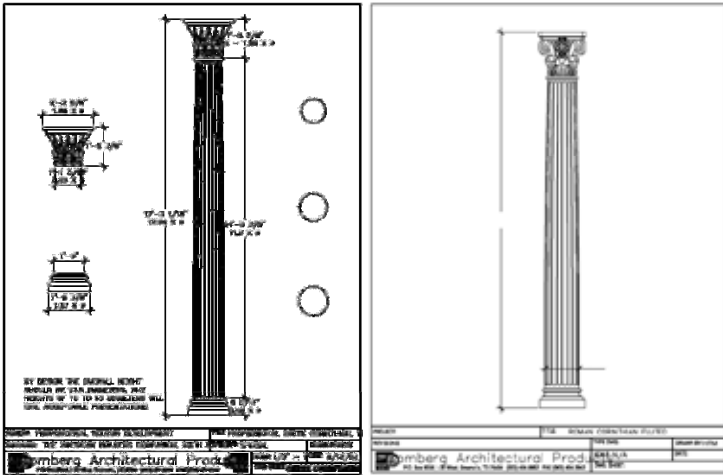

Corinthian pilasters in GFRC (The Stromberg stone faced architectural fiberglass)

Corner Pilaster

An engaged pilaster, located at the corner of the building or colonnade.

Cornice

A molded horizontal projection that crowns the top of a wall where it meets with the edge of a roof. The term cornice, is also used to refer to the top section of an entablature (resting on the frieze) or to refer to the ornamental molding at the top of a door or window surround. GFRC (glass fiber reinforced concrete) and GFRP (architectural fiberglass) cornices offer architects a number of design possibilities. Shape selection is virtually unlimited. Cornices can be designed in traditional or contemporary styles. Custom shapes can be used, or you can select a stock profile from our extensive collection. Dentils, reveals, cantilevered projections, carved details, can all be incorporated into the cornice. At Stromberg, shape selection is virtually unlimited. Stone textures, acid washed concretes, colors, terra-cottas, and even metallic are all possible finish options.

The light weight and strength of Stromberg GFRC and Architectural Fiberglass, combined with modern technology and repetitive casting techniques makes it affordable to use complex shapes and profiles.

Because of the relatively light weight and strength of GFRC and Architectural Fiberglass, the cornice can cantilever beyond the buildings structure without costly additional support. Wind and other loads are transferred back to the building's structure.

Cornices provide the visual finishing touch to the roof line. Cornices in glass fiber reinforced concrete and architectural fiberglass also serve the purpose of shading to reduce energy costs and protecting the wall below from the weather.

Cornices should be detailed to maintain a continuously uniform water barrier at the interface between wall and roof components. Roof membrane and flashing can extend under the cornice, or roofing can be brought up the backside and over the top of the cornice, covering the entire back panel including caulk joints. Stromberg GFRC and GFRP offer you a number of options, depending upon your unique requirements. If you need further assistance, please give us a call or email. We are here to help.



Cornice Return

Is the term for the continuation of a cornice, either back to the wall where it terminates, or in a change direction, at a gable end.

Corona

The overhanging vertical member of a cornice in classical architecture.

Cresting

A decorative design along the ridge of a roof, cornice, coping or parapet. Usually highly ornamented and often perforated. Often found in the Chateau style, Second Empire style, and Queen Anne style, but also found on other styles. GFRC (glass fiber reinforced concrete) and GFRP (architectural fiberglass) cresting incorporates stainless steel or other non-corroding anchors which allow it to be bolted to the structure below.



Wall top cresting or crenellation in cast stone

Crocket

Gothic ornaments of medieval origin, usually plant like in form, placed along the edge of the sloping surface of pinnacles or spires. Most often seen in Gothic revival architecture. GFRC (glass fiber reinforced concrete) and GFRP (architectural fiberglass) Crockets are generally cast with a stainless steel or noncorrosive metal all thread through them to allow for attachment to the structure.

Cupola

Structure located on a roof or a dome, with a circular polygon will base. Often louvered for ventilation, sometimes set with glass or stained-glass. The word comes from the Latin 'cupella' or the Greek 'kupellon')

meaning a small cup (A cupola resembling an upside down cup.) A cupola that is lighted is sometimes referred to as a lantern. A Cupola with access for viewing out of to view the scenery is often called a belvedere, from the Italian term for fair view. GFRC (glass fiber reinforced concrete) and GFRP (architectural fiberglass) cupolas may be designed as one piece units, if small enough to be transported. Larger cupolas of GFRC (glass fiber reinforced concrete) and GFRP (architectural fiberglass) are generally made in segments that are pre-fitted at the factory, disassembled for shipping, reassembled on the ground at the site, and then hoisted into place with a crane. GFRC and GFRP cupolas may be custom designed or may be selected from a catalog of stock the cupola designs. In most cases a glass fiber reinforced concrete cupola sets over a roof membrane, as a decorative element on the roof. Flashing and waterproofing is therefore simplified.

**Cushion Capital**

Capital of the Romanesque style and Gothic style that somewhat resembles a cushion.

Cyma

A molding with the double curved shape of an S in section.

Date Stone

A panel or "stone" of GFRC, inscribed with the date of completion of the building, and sometimes other information. The glass fiber reinforced concrete date stone may be a cornerstone, a plaque or keystone.

Dentil

One of a row of “tooth like” blocks, set in a molding or cornice. These are part of the classical ornamentation of the Ionic, Composite, Corinthian and Doric orders. Found in Federal style, Adams style, Classical Revival style, French Eclectic architecture, Georgian style, and Greek revival architecture. GFRC (glass fiber reinforced concrete) and GFRP (architectural fiberglass) moldings may be cast with the dentils as part of the molding, or the dentils may be cast separately and attached after casting. It is important that dentil molding and cornice with dentils be properly laid out so that the dentil spacing is uniform. This is generally done by the manufacturer in the shop drawings stage.



Dome

A roof structure generally shaped like a segment of a sphere, but may also be polygon or oval in plan. Large GFRC (glass fiber reinforced concrete) and GFRP (architectural fiberglass) domes are generally cast in pie shaped segments, and assembled on-site. Smaller domes, generally less than eight to 10 feet diameter, may be cast as one piece units, or in segments. If the dome is a decorative element to be viewed from the exterior only, the roof is put in place, and the dome placed above it. Similarly if the dome is to be viewed from the interior only, it may be suspended from the ceiling structure above it. If the domes are to be viewed from both the interior and the exterior then a double dome is required with insulation placed between the inner and outer dome. Exterior glass reinforced concrete and architectural fiberglass domes may be molded smooth or textured, with ribs or even with the molded in shape of roof tile, or glazed mosaic tile. Interior domes in GFRC (glass fiber reinforced concrete) and GFRP (architectural fiberglass) may be smooth, ribbed, or coffered. In some applications both an exterior dome of GFRC or architectural fiberglass, and an interior dome of GFRG or architectural fiberglass are used. Between the inner dome and outer dome, the dome cavity may be insulated.



Architectural fiberglass domes by Stromberg, Atlantis, Bahamas



Dome in GFRG

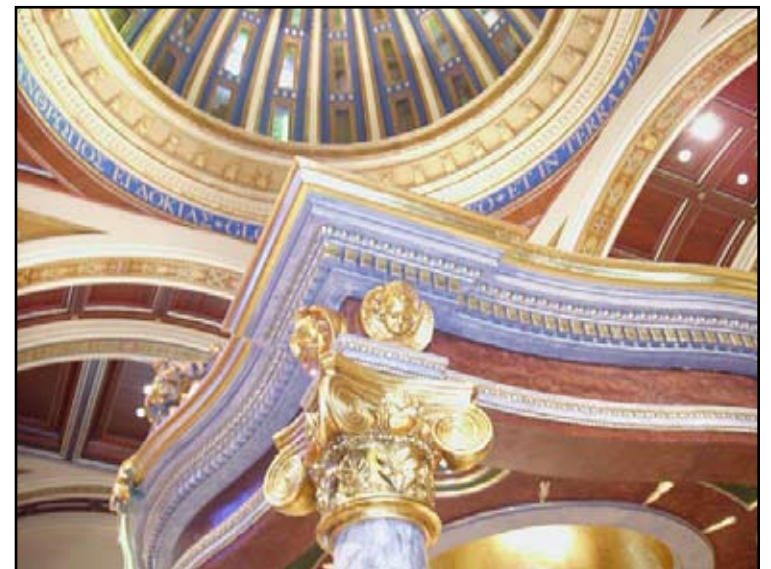

Interior GFRG domes

Door Surround

A structure or decorative element around the doorway. GFRC (glass fiber reinforced concrete) and GFRP (architectural fiberglass) door surrounds range from the simple to the very ornate and are used with every style of architecture.



Ventura Door Surround on office building (Also shown is M30 banding, G29 balustrade and 24" diameter Corinthian columns.) The Ventura Surround is adjustable in size.

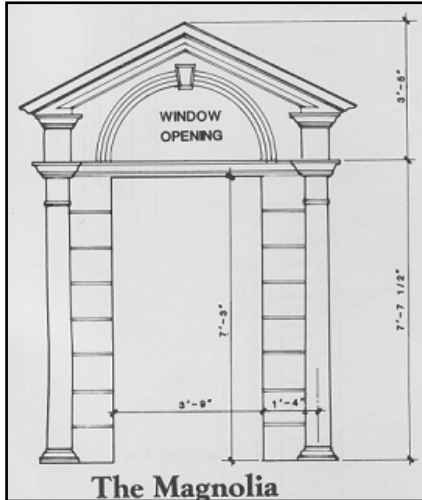
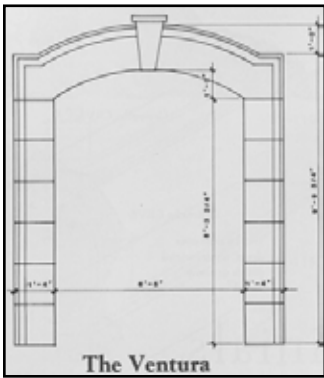

The Magnolia Door Surround features two columns (pilasters) and a angular pediment. The size is adjustable.



Entry surround of M80 molding

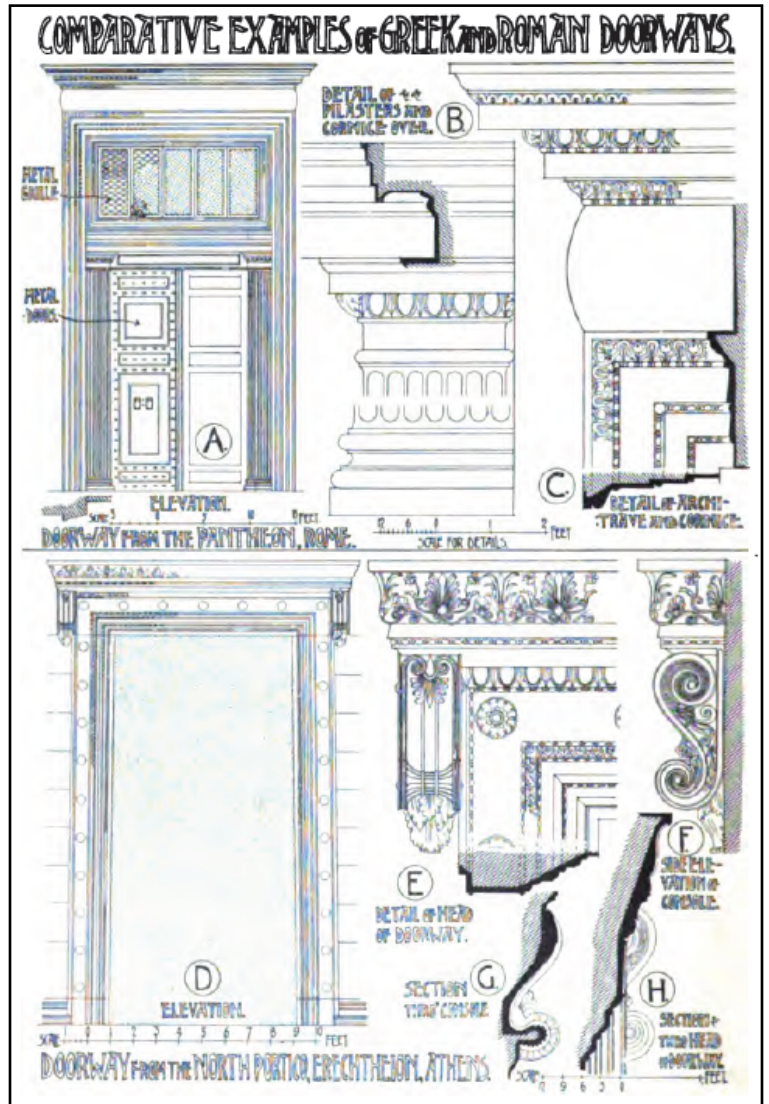

Doric Capital

The top or capital of a column or pilaster of the Doric order.

Doric Order

The Doric Order is the oldest and simplest of the three Greek architectural orders and was invented by the Dorian Greeks. The Doric order is characterized by sturdy proportions and a simple capital. The columns are thicker relative to their height than in the other orders. The Greek Doric column is fluted and has no base. The Roman Doric is usually not fluted and has a base. The entablature is deeper and visually heavier than that of either the Ionic or Corinthian Orders. Doric columns are available in GFRC (glass fiber reinforced concrete) and GFRP (architectural fiberglass) in a variety of standard sizes with shaft diameters typically in even numbered increments (12 inch, 14 inch, 16 inch, etc.)

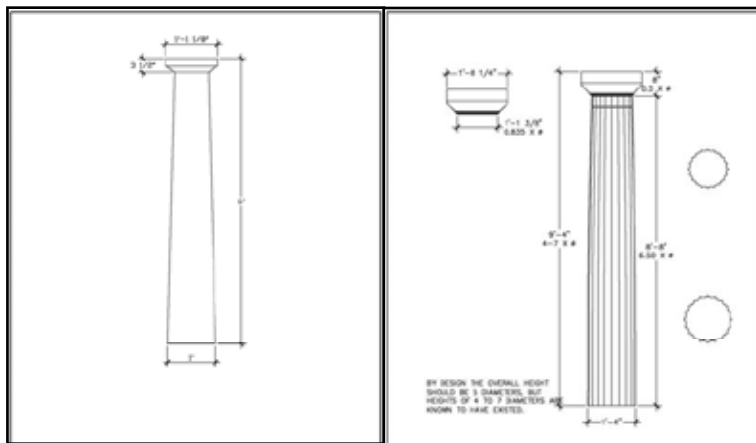
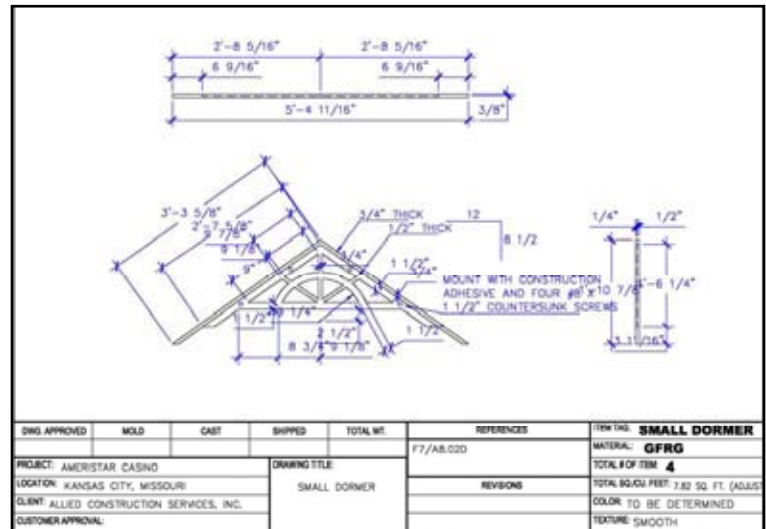

Double Bellied Baluster

A baluster with two vase shaped "bellies," the same profile on the upper and lower half. GFRC and Architectural Fiberglass balusters are available in a large selection of standard profiles.

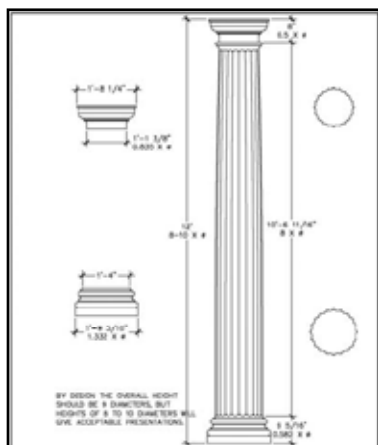

Dormer

And architectural element which projects from a sloping roof. Dormers usually contain a vertical window or louvers. GFRC (glass fiber reinforced concrete) and GFRP (architectural fiberglass) dormers are generally not part of the roof structure but are cast separately.

Because the great variety of dormers, GFRC and GFRP dormers are generally custom-made for the needs of a specific project. Include such variations as the arch dormer, eyebrow dormer, Flathead dormer, hip dormer, Mission dormer, Palladian dormer, pointed dormer, random dormer, triangular dormer and through the cornice wall dormer.



Example of a double bellied baluster



Double bellied balustrade

Double Lancet Window

A window surround with two pointed Lancet windows side-by-side.

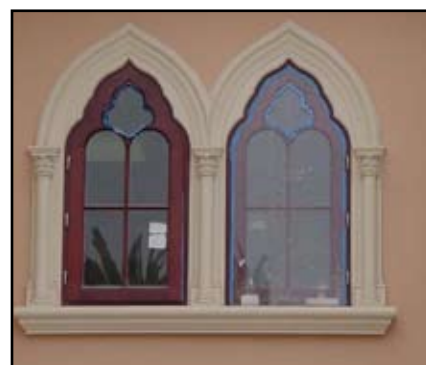

Double Lancet window

Dowel

Cylindrical metal rod often used to secure two pieces of GFRC together, or to secure GFRC (glass fiber reinforced concrete) to another material. Dowels for GFRC are generally stainless steel or galvanized steel. Shown are typical dowel anchors for GFRC.

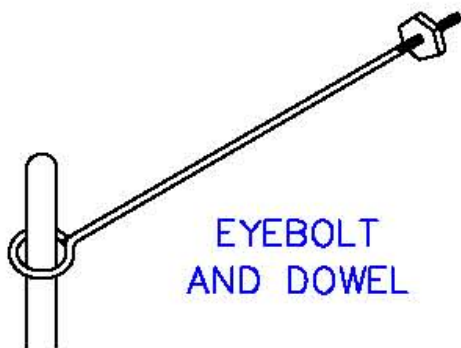
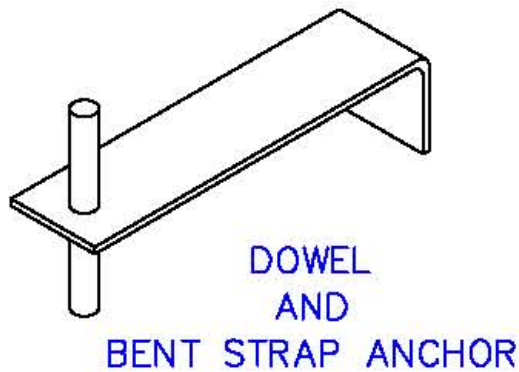
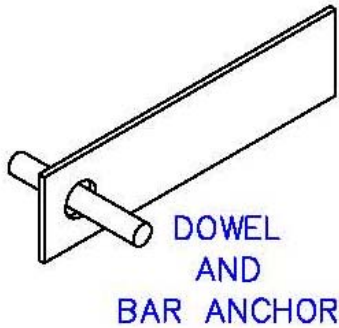
**Drip Molding**

A horizontal molding over a door or window designed to channel rainwater away from the wall surface and as a decorative element.

Eaves

The underside of the part of the roof that projects beyond the exterior wall. GFRC (glass fiber reinforced concrete) and GFRP (architectural fiberglass) eaves may be coffered or plain.



Highly ornamented eaves

Egg and Dart Molding

An ornamental molding with a repeating pattern of egg shaped ornaments alternating with dart shaped ornaments.



Egg and dart molding GFRG

Egyptian Revival

A style of architecture suggestive of the architecture of ancient Egypt. This architecture usually exhibits elements such as Lotus capitals, columns that bulge or that imitate papyrus stocks, Egyptian Gorge, winged sun discs, etc.



Egyptian Revival Columns and Capitals, Cheesecake Factory Restaurant (GFRG)

Egyptian Gorge

Also known as Egyptian cornice, Cavetto cornice, Gorge-and-roll cornice. Consisting of a large cavetto molding (round concave molding continuing at least a quarter circle) sometimes decorated with vertical leaves, and a roll molding below.

Elizabethan Architecture

An English style of architecture, it was the transitional style between Gothic architecture and Renaissance architecture.

Elliptical Arch

Any arch having the shape of half an ellipse.



Engaged Column

A column, attached to a wall. GFRC (glass fiber reinforced concrete) and GFRP (architectural fiberglass) engaged columns, may be half round or three quarter round.



Entablature

An entablature, is a horizontal band and molding supported by columns. Entablatures or horizontally divided into three basic elements: the architrave (the upper most portion;) the frieze (the middle section,) and the cornice (the top section.) The proportions and details of an entablature are different depending on the order (Doric, Tuscan, Ionic, Corinthian or Composite.) GFRC (glass fiber reinforced concrete) and GFRP (architectural fiberglass) entablatures may be cast as U shaped sections to wrap a structural beam or be hollow and feature internal ribs for stiffening or an internal steel frame.



Entablature

Entasis

A slight convex curve added to the tapered profile of classical columns. Entasis is used to overcome the optical illusion of concavity of straight sided shafts.

Entry Surround

A door surround at the main entry to a home or building.



Entry surround (the Ventura) by Stromberg

Equilateral Arch

A pointed, centered arch whose radius of curvature is equal to the width of the opening.

Eyebrow Lintel

A lintel over a door or window, with a slight arch to it. GFRC (glass fiber reinforced concrete) eyebrow lintels may be designed to be structural or non structural.

Facade

The exterior skin of a building, which is considered to be the architectural face or front.



Chico's Facade

Federal Style

Style architecture that developed in the postcolonial era in America. It was greatly influenced by the work of Robert Adam. Buildings constructed in the Federal style may contain the following architectural elements: large entrance porticos, columns and pilasters, cornice with moldings, quoins, festoons, garlands, urns, swags, dentils and egg and dart moldings. Many GFRC (glass fiber reinforced concrete) and GFRP (architectural fiberglass) elements are available as stock patterns or maybe custom fabricated in the Federal style.

Festoon

The decoration of suspended flowers, fruit, foliage, ribbons, etc. found in the Beaux Arts Style, Colonial Revival, Adam style and Federal style. Also known as garland or swag.



Festoon plaque over window • Part of the restoration of North Texas State University

Fieldstone

Construction of individual stones for walls and chimneys. GFRC (glass fiber reinforced concrete) and GFRP (architectural fiberglass) field stone panels are available in a variety of stone types, colors and textures. GFRC and GFRP field stone panels allow for fast installation and quality workmanship.



Fieldstone panel for "lighthouse" cast in GFRC (glass fiber reinforced gypsum) for interior use. Fieldstone panels could also be cast in architectural fiberglass or GFRC for exterior use.

Finial

An ornament that tops a gate pier, pinnacle, spire or pediment. Typical GFRC (glass fiber reinforced concrete) and GFRP (architectural fiberglass) finials might be urns, pineapples, acorns, obelisks, etc.



Draped Urn finial

Fireplace Mantles

A shelf or entablature over a fireplace opening. Stromberg GFRC offers a selection of stock moldings and corbels that are used as fireplace mantles. Glass fiber reinforced concrete, being non combustible, is an ideal material for fireplace mantles.

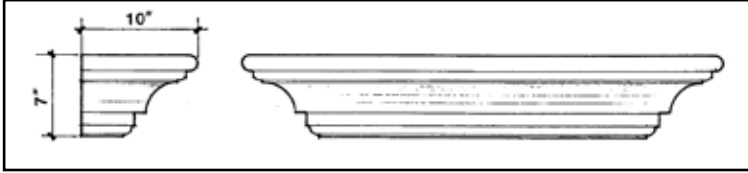
**Fireplace Surround**

The frame around a fireplace opening. The surround consists of the side supports, which may be columns, engaged columns, pilasters, corbels, ancones or moldings, and the top entablature or shelf. GRC is an excellent choice for fireplace surrounds since it is non combustible. Glass fiber reinforced concrete fireplace surrounds can be cast in a texture and color to replicate cut stone or cast stone.

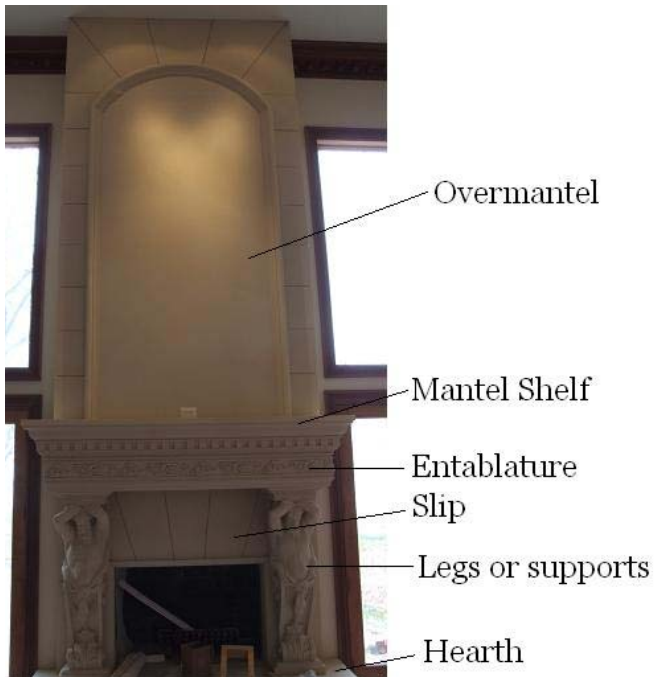
**Fireplace Hearth**

The floor of the fireplace opening. GFRC fireplace hearths are designed to extend into the room and the glass fiber reinforced concrete provides the non combustible material to protect the floor.

Flat Keystone Arch

A flat arch or lintel with a keystone at the center.

**Fleur-de-lis**

From the French word for "flower of the lily". A stylized three-petaled iris flower tied by an encircling band, once used as the heraldic bearing of the French royal family (chosen by Charles V.) used on coats of arms and later used by English kings and royalty. An ancient emblem, the Empress Theodora bore one on her crown (approximately A.D. 527.) The three "petals" of the fleur-de-lis have also been used to represent the Holy Trinity.



Fleur-de-lis in architectural fiberglass

Fluting

Shallow vertical grooves on a column or pilaster shaft.

Foil

From the French word "foil" meaning "leaf". A leaf-shaped curve or lobe, formed between points called cusps inside an arch or circle. Used in Gothic style

(continued on next page)



Foil - continued

tracery windows. The number of foils is indicated by a prefix, e.g. trefoil (three lobes,) quatrefoil (4 lobes,) cinquefoil, sexfoil, multifoil. Found in Gothic and Gothic Revival Styles and others.



Quatrefoil Medallion

French Renaissance Style

The French version of the Renaissance style, the architectural style developed in early 15th century Italy and spread to France during the rebirth (rinascimento) of classical art and architecture.

Heavily influenced by Vitruvius's Treatise on Architecture, originally written in the time of Augustus, and later published in Rome in 1486. GFRC (glass fiber reinforced concrete) is uniquely suited to the replication of Renaissance style architectural elements. Renaissance style GFRC, columns, capitals, fireplace mantles, balustrade, ceilings, garden urns and planters, etc are available as stock patterns, or able to be custom produced.

Folly

A term of endearment for a structure that is functionally useless but designed for visual interest or effect, such as a false ruin in a garden or a gazebo that is designed to complete a garden vista or scene.

Fret

A type of running ornament consisting of repeated and symmetrical figures, often in relief, contained within a band or border. Old French: "fret" meaning grating.

Frieze

The middle section of the entablature. Above the architrave and below the cornice.



Jungle Frieze in architectural fiberglass. Siegfried and Roy Garden Mirage Las Vegas.

Gable

Known as the pediment in Classical architecture. The gable is the triangular portion of the wall, between the enclosing lines of a sloping roof. Gable cornice in GFRC (glass fiber reinforced concrete) or GFRP (architectural fiberglass) is the cornice that is used at the gable.

Gable Window

A triangular window top that is shaped like a gable or pediment.

Gargoyle

A grotesque figure, projecting from a building. A gargoyle may function as a waterspout or be purely decorative. Found in the Gothic, Queen Ann and Tudor Styles of architecture. GFRC and Architectural Fiberglass gargoyles are available as stock and custom designs. Generally attached with threaded rods.



Gargoyle in architectural fiberglass (GFRP)

Garland

A decoration of suspended flowers, fruit, foliage, ribbons, etc. found in the Beaux Arts Style, Colonial Revival, Adam style, Federal style and others. Also known as a festoon or swag. Garland may be incorporated into GFRC (glass fiber reinforced concrete) and GFRP (architectural fiberglass) elements such as door heads, planters, panels, cartouches, etc.



Gargoyle Finial in GFRC and cast stone

Gazebo

A small garden house, normally round or polygonal in plan, designed for providing a view. GFRC (glass fiber reinforced concrete) and GFRP (architectural fiberglass) gazebos typically feature GFRC columns, a GFRC or Architectural Fiberglass entablature and a GFRC or Architectural Fiberglass dome or roof. Gazebos are sometimes referred to as a garden house or summerhouse.

**Georgian Style**

The dominant style of architecture in England during the 18th century, named Georgian after the reigns of the three King Georges from 1714 to 1820.

Inspired by the ideals of Andrea Palladio (1508-80) and Roman classical architecture popularized by Robert Adam (1728-1792). In the USA, Georgian is similar to and is also referred to as Federal. In New England, Colonial architecture is also referred to as "Georgian". GFRC (glass fiber reinforced concrete) is uniquely suited to the replication of Georgian style architectural elements, including Georgian style GFRC columns, capitals, fireplace mantles, cornice, entryways, window and door surrounds, balustrade, ceilings, garden urns and planters, cupolas, domes, dormers, quoins, porticos, keystones, etc.

Gibbs Surround

A window or door surround with rusticated alternating large and small blocks of stone. Named after the Scottish architect James Gibbs (1682-1754,) considered by many to be the most influential church architect in London during the early 18th century.

Gothic Architecture

The architectural style of the high middle ages in Western Europe. Typified by the great cathedrals, characterized by their flying buttresses, ribbed vaults, tracery, pointed arches, rose windows, etc.

Gothic Revival

The style of architecture following the forms and spirit of Gothic architecture. GFRP (architectural fiberglass) and GFRC (glass fiber reinforced concrete) architectural elements for Gothic revival architecture include GFRC ashlar masonry, GFRP and GFRC battlements, decorative brackets, foliated ornaments, finials, hood moldings, pinnacles, Crockets, rose windows, pointed arches, quatrefoils, trefoils and turrets. Gothic revival chimneys often feature high, ornamental chimney stacks and chimney pots. GFRC (glass fiber reinforced concrete) and GFRP (architectural fiberglass) rose windows and lancet windows as well as various types of tracery are also produced, as well as glass fiber reinforced concrete Gothic columns, Gothic arches and even gargoyles.



Gothic revival style facade in architectural fiberglass

Grapevine

A type of ornament either running or enclosed usually consisting of the grape vine with leaves, and clusters of grapes. Used as a decorative element for cornices and interior moldings.

Greek Key

Also known as Greek fret. A running ornament that resembles the head of an old-fashioned skeleton key, and usually formed bands and moldings arranged in rectangular forms. The Greek key pattern is frequently used in GFRC (glass fiber reinforced concrete) and GFRP (architectural fiberglass) cornice, molding and door surrounds in the Greek revival style.

Greek Revival Style

Style architecture based on ancient Greek forms in architecture such as the Greek orders (Doric, Ionic and Corinthian). Buildings in the Greek revival style were generally rectangular in shape or a combination of rectangles. GFRC and Architectural Fiberglass elements produced the Greek revival style include raked cornice, classical pediments, anthemion, dentils and egg and dart molding. Greek revival style columns in GFRC (glass fiber and first concrete) and GFRP (Architectural Fiberglass) include round or square columns especially Doric columns, Ionic columns and Corinthian columns. Greek revival style entryways in GFRC (glass fiber reinforced concrete) and GFRP (architectural fiberglass) generally wide and imposing and framed by pilasters or engaged columns.

Grille

A grating or pierced panel, used to cover, decorate or protect an opening. GFRC (glass fiber reinforced concrete) and GFRP (architectural fiberglass) grilles (or grills) can be produced in a variety of sizes and shapes.

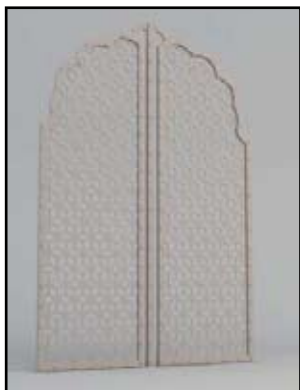
**Groin Vault**

Formed by two barrel vaults intersecting. The groin is the edge or ridge where the two vaults intersect. GFRC (glass fiber reinforced concrete) being relatively light and moldable, is a perfectly suitable material for the production of barrel vaults and groined vaults.

Guilloche

Type of ornament consisting of circular openings created by two or more curved bands overlapping each other in a continuous series. Guilloche details in GFRC and Architectural Fiberglass are generally used in cornice, banding or moldings.

Half Baluster

When a balustrade connects to a wall, pier or plinth, a half baluster may be used. Also known as an engaged baluster.

Half Column

Column that is engaged to wall projects from the wall by about one half its diameter. GFRC (glass fiber reinforced concrete) and GFRP (architectural fiberglass) half columns are available in all of the classical orders (Doric, Tuscan, Ionic, Corinthian) as well as custom column styles and sizes.

Head

The head is the top horizontal cross member of a door, window, fireplace surround or other opening. Window and door heads in GFRC and Architectural Fiberglass may be plain or ornamented.

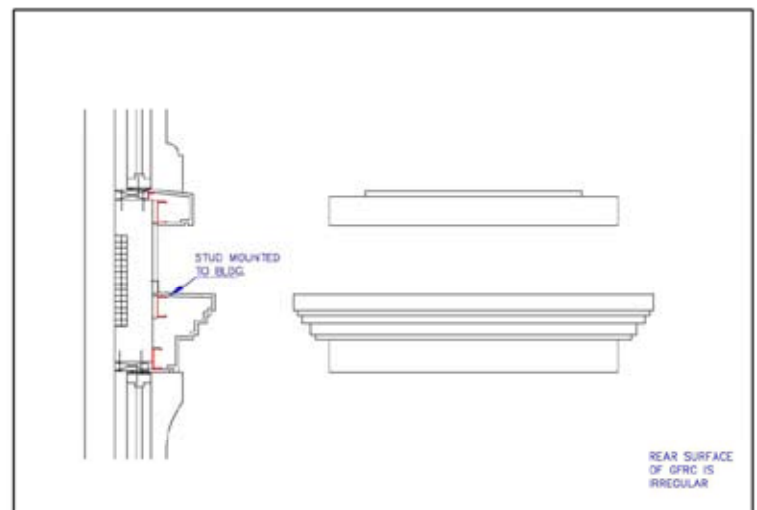
**Hearth**

The part of the fireplace floor that extends into the room. GFRC (glass fiber reinforced concrete) being noncombustible, makes an ideal material for a fireplace hearth. When used as a hearth, glass fiber reinforced concrete is typically cast solid or has ribbing added to the underside. The hearth is buttered full with mortar, and is set in a full mortar bed.

Hearthstone

The stone or stone like part of the fireplace floor that extends into the room. Synonymous with hearth although a hearthstone typically refers to a one piece stone or (GFRC) hearth. When used as a hearth, glass fiber reinforced concrete is typically cast solid or has ribbing added to the underside. The hearth is buttered full with mortar, and is set in a full mortar bed.

High Relief

A type of bas-relief were the sculpted or molded figures project to a larger degree from the background plane. Also known as alto-relievo. For the reproduction of bas-relief in glass fiber reinforced concrete or architectural fiberglass, a model is produced in clay, wood or plaster. A mold is then made using silicone rubber and a hard shell of fiberglass. Once the mold is removed from the model, the GFRC or Architectural Fiberglass are cast. Depending on the size of the glass fiber reinforced concrete or GFRP bas relief, a metal armature on the interior, generally galvanized or stainless steel, may be cast in. The casting is then sand blasted or acid washed to remove the cement film from the surface of the glass fiber reinforced concrete and to obtain the desired finish.

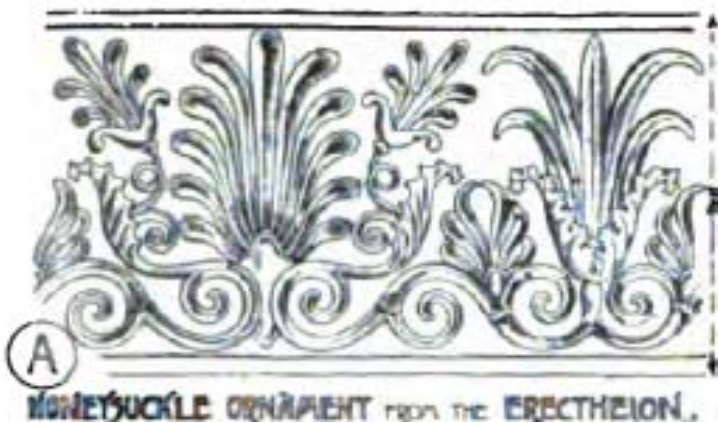

Honeysuckle Ornament

Hood

Horizontal element or covering above a door or window that provides shade or shelter or a decorative element. Above a fireplace or cooking area, the hood is a covering over the fireplace or grill that diverts smoke up the chimney.

Hood Molding

Protecting molding over a door or window, usually intended to direct rainwater from the face of the wall. The term hood molding is generally used when the molding is arched and is known as a label molding if it extends horizontally above the opening. Typical of the Chateau, English country, and Italianate Styles.

Horseshoe Arch

A rounded arch consisting of more than half a circle, so that the widest span of the arch is larger than the opening at the bottom of the arch.

Impost

A decorative element found at the spring point of an arch.

Intercolumniation

The clear span between two adjacent columns in a row of columns. Measured at the base of the column shafts. If the space is 1 ½ column diameters it is known as pycnostyle. If the space is two column diameters is known as systyle. 2 ¼ column diameters is known as eustyle. Column spacing of three column diameters is known as diastyle. And column spacing of four column diameters is known as areostyle.

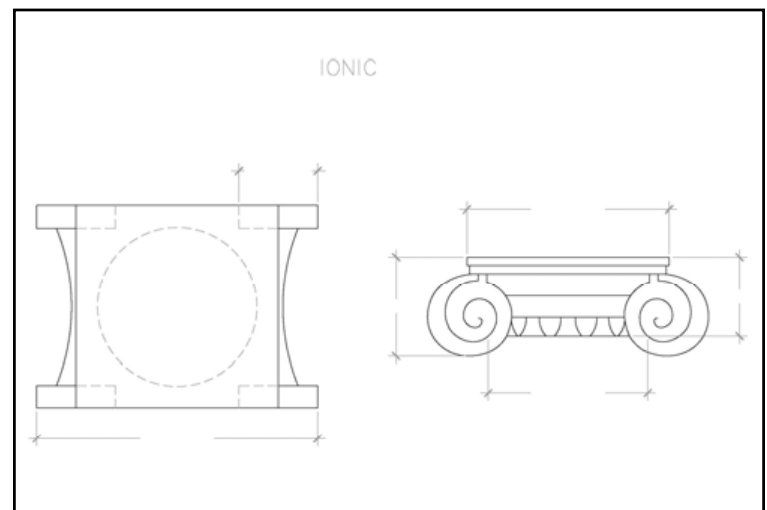
**Ionic Capital**

The column capital of the Ionic order. The volutes on this column capital resemble a stylized form of rams' horns or nautilus shells.

Ionic Order

One of the five orders of classical architecture. The Ionic Order takes its name from Ionia, the Greek name for those parts of Asia Minor which were settled by people of Greek origin (now modern day Turkey). The curls or "volutes" on its capital resemble rams' horns, but may have been derived from other natural spirals, from the nautilus, the lotus flower or seashells.

To the ancient Greeks, the slim proportions and elegance of the Ionic Column represented the female form, while the sturdiness and simpler details of the Doric Column represented the male.

Ionic columns were widely used by the Romans, and the style was adapted and used by Robert Adams. Ionic columns are found in architecture of the Classical Style, Adams Style, Federal Style, Neo Classical style into the present.

Ionic columns are typically slender, at 8 to 12 diameters in height (a 1' diameter column would be 8' to 12' tall). GFRC (glass fiber reinforced concrete) and GFRP (architectural fiberglass) Ionic columns are available from stock molds in column shaft sizes of even diameter (12", 14", 16" etc.). Column shafts may be made in halves to wrap a structural member or made in stacking sections. Column shafts may also be one piece if they are small enough to be transported.

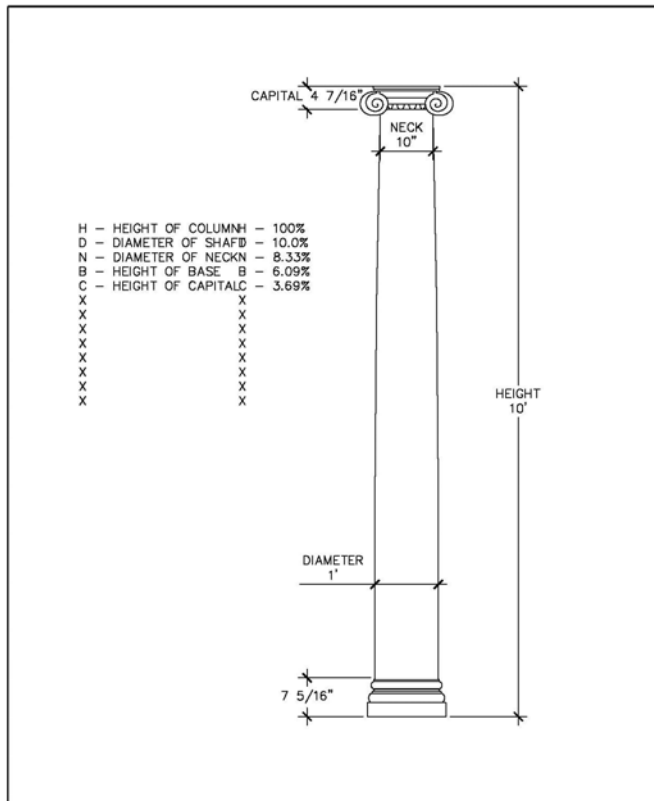
***Italianate Style***

Style architecture influenced by Italian villas. GFRC (glass fiber reinforced concrete) and GFRP (architectural fiberglass) Italianate elements include columns, balustrade, belt courses, balustraded balconies, projecting cornices with decorative brackets and corner quoins. Roof cupolas, belvedere and domes, brackets and other Italianate GFRC and GFRP elements are available.

Italian Renaissance Revival

Architectural style influenced by the Renaissance palazzi of Italy. Appropriate GFRC and Architectural Fiberglass elements include an elaborate belt course between stories, rusticated corner quoins, pilasters and a large cornice. Rounded arches, balcony balustrade and frequently rooftop balusters and balustrade are also featured. Door and window surrounds often featured pedimented heads.

Jack Arch

The Jack arch is the same as a flat arch.

Jamb

Jamb is the name for one of the vertical members on either side of a door, window or fireplace surround.

***Jeffersonian***

Also known as Jeffersonian classicism or the Jeffersonian style, is a style architecture based on architecture of Thomas Jefferson. It features many elements of the classical revival style. GFRC (glass fiber reinforced concrete) and GFRP (architectural fiberglass) elements that are available in the classical revival style include triangular pediments, columns in the Doric or Tuscan

(continued on next page)

Jeffersonian - continued

order, Roman Ionic and Corinthian orders. Dentils, triglyphs, fireplace surrounds, door surrounds, moldings, cornice, fireplace mantles and balustrade.



Keystone

The wedge-shaped block at the top center of an arch. GFRC and Architectural Fiberglass keystones may be plain or embellished.

Label Molding

An exterior horizontal molding, generally above a window or door, used to direct rainwater from the face of the wall and the opening below.

Lancet Arch

A pointed, Gothic style arch.

Lancet Window

A narrow window shaped like a Lancet arch.



Lancet Windows

Light Cove

A molding with a recess for concealed lighting.



Column in architectural fiberglass with a GFRG capital and GFRG light cove.



Exterior GFRC light cove

Lintel

A horizontal shape above the door or window opening. GFRC (glass fiber reinforced concrete) and GFRP (architectural fiberglass) lintels are not structural in and of themselves, but are used to wrap and protect steel or concrete structural lintels.



Loggia

An elaborate gallery or porch that is either connected to or contained inside a larger structure. It is either colonnaded or arcaded and usually placed in a prominent location. Loggias are open to the outside on at least one side, to provide a protected outdoor rest area. When colonnaded loggias are open on only one side, they typically feature pilasters on the opposite wall. Loggias may feature balusters between the columns. GFRC columns for Loggias are available in all the classical orders including Tuscan columns, Doric columns, Ionic columns and Corinthian columns and with smooth or fluted columns shafts.

Molding

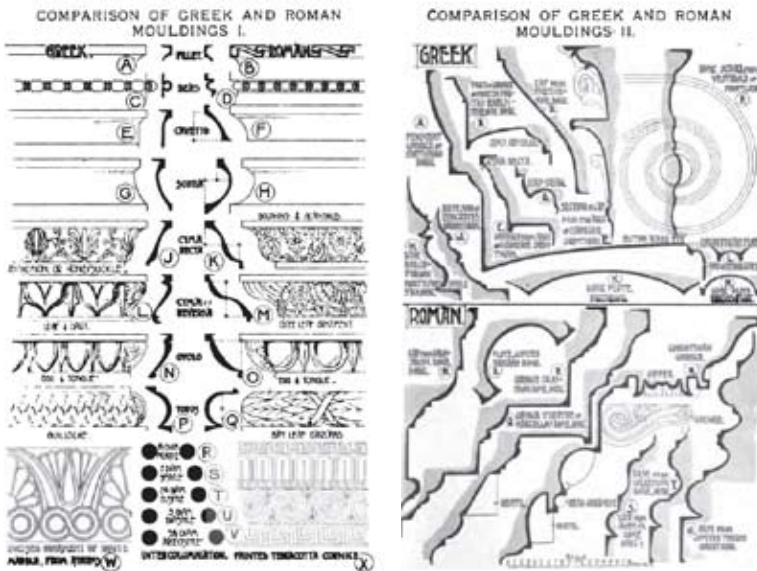

Neoclassical Style

A reinterpretation of classical Greek and Roman architecture. Neoclassical style includes Classical revival style, Greek revival style and Federal style. Characteristics of the neoclassical style include large porticos and columns of the Greek and Roman orders. Columns and pilasters of the Corinthian, Ionic and Doric order.

Order

In classical Greek architecture the orders are Doric, Ionic and Corinthian.

The Romans added the Tuscan and Composite. Each order carries its own entablature, column and base.

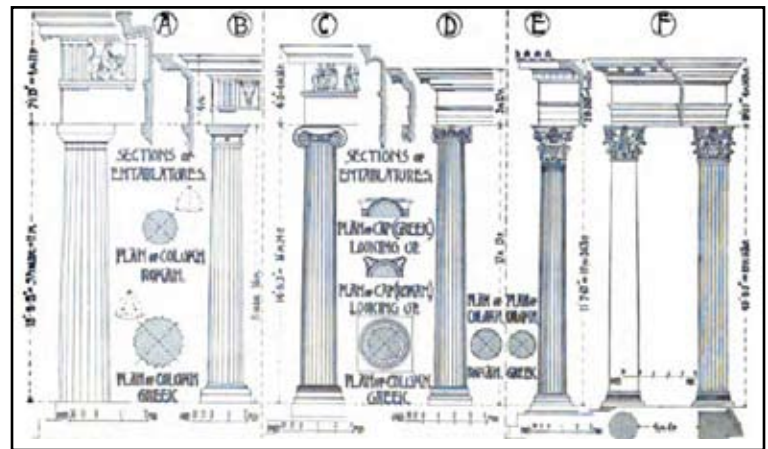

Palladian Window

Style of window that consists of three parts: A large arched top central window with two smaller rectangular windows on either side usually topped by lintels.

Palm Capital

A type of column capital that resembles the crown of a palm tree.

Pavilion

1. An ornamented structure in the garden. 2. A detached or semi detached structure used for specialized activities or entertainment, at a park, a fair or event. 3. A pronounced structure projecting from the building facade.



Pedestal

In classical architecture the pedestal was the support for the columns, and consists of three parts the cornice or cap; the central dado; and the base or plinth.

Pediment

A triangular shaped gable consisting of a tympanum with raked cornices on either side. In classical architecture the pediment was the low triangular gable, usually above a door, a window, or crowning a portico.

**Pendant Drop**

A suspended carved element.

Pendentive

The curved transition wall surface between a dome, or a dome drum, and the wall below.

Pentastyle

A portico with five columns.

Pergola

An open garden structure designed for the support of climbing plants. Design with regularly spaced columns or post.



Pergola with climbing roses

Peristyle

A colonnaded walkway surrounding the exterior of the building or an open area.

Pilaster

A flat column or pillar, attached to a wall.



Architectural Fiberglass Corinthian pilaster

Pineapple Ornament

The carved element that resembles a pineapple or a pine cone. Pineapple ornaments are said to be the symbol of hospitality. Pineapple ornaments are used as finials for gates or pier caps, or over doorways.

Pinnacle

A tapered upright structure rising from the roof of a building or used as a finial.

Plaque

Inscribed tablet fixed to the surface of a wall.

Plinth

The bottom most square or rectangular base of a column, pilaster pedestal or pier.

Polychromed

1. Masonry pattern of contrasting colors, such as horizontal bands across the facade or banded arches, windows or doorways. 2. Surface made up of a variety of colors to emphasize the difference between various elements.

Porte Cochère

The covered entry way for an automobile to protect the people arriving by vehicle from inclement weather.



Portico

Covered entrance with a roof supported by columns, and usually with a pediment above.

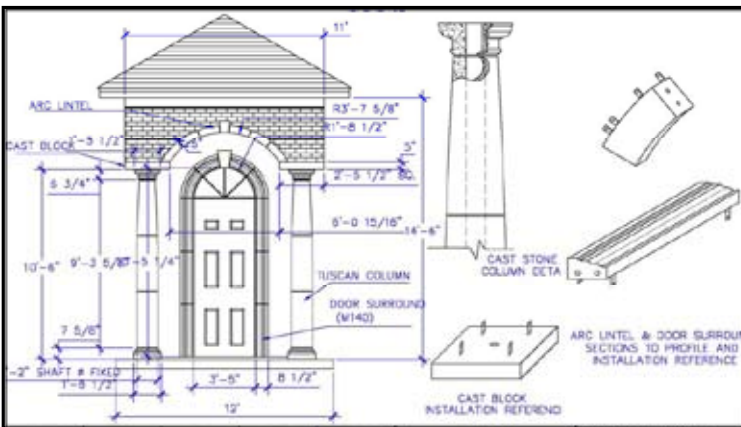

Prairie Style

A uniquely American architectural style, associated with the works of Frank Lloyd Wright and Louis Sullivan.

Quatrefoil

A four lobed, clover shaped pattern, most common in Gothic, Venetian, and Gothic revival architecture.



Window surround in glass fiber reinforced stone by Stromberg

Quoin

Stone set at the external corner of a building, used to accentuate corner.



Rain Screen

A cladding method designed to minimize rain water intrusion into walls. The GFRC and Architectural Fiberglass rain screen systems combine a vented exterior cladding, an air cavity / drainage layer and a water resistant support wall.

Stromberg GFRC Rainscreen System

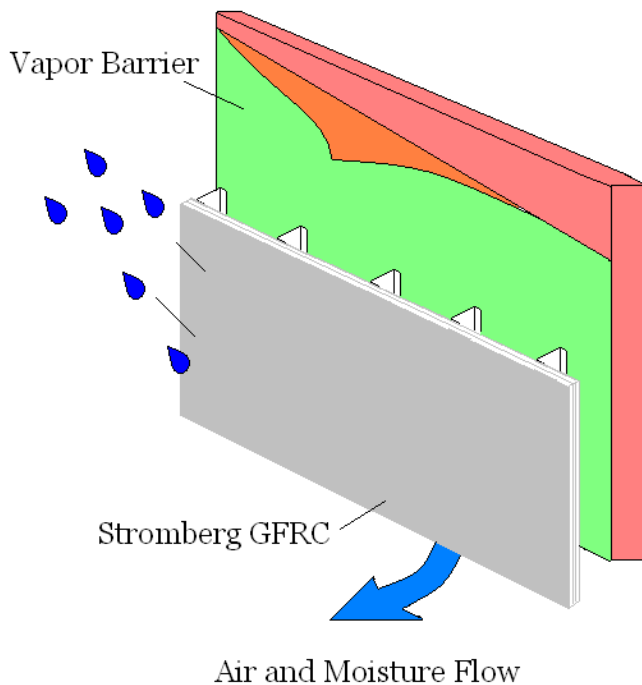
**Rafter Tail**

The rafter tail is the external part of the Rafter that overhangs the wall at the eaves.

Raked

Term used to describe a cornice or a molding that is inclined. For example the raked cornice of a triangular pediment.

Return

The right-angle turn of a molding. A cast stone molding with a return is one that makes a right angle turn back to the wall as a way of terminating the molding.

Reveal

The exposed edge portion of molding between its outer face and a groove or opening, such as a window or door.

Rope Molding

The molding carved or shaped to resemble a twisted rope.

Rosette

Square or round pattern with a central floral motif.

Rotunda

The circular space in a building, especially when covered by a dome.

Round Dormer

A dormer with a circular window.

Roundel

Circular window, panel or decorative element.

Running Ornament

Running ornament refers to any ornaments in which the design is repetitive and continuous.

Rusticated Stone

Type of stone masonry with strongly emphasized recessed joints. Each individual masonry unit may have its edges chamfered or otherwise tooled to accentuate the joints.

Scallop

Series with continuous curves, made up of semi circular segments and resembling the shell of the scallop.

Scotia

Deep concave shaped molding. Especially refers to the concave shape of a classical column base.

Scroll

A spiral formed ornamental shape, either as part of a running ornament, or as part of a volute as on an Ionic capital or bracket.

Second Empire Style

An architectural style named after the French second Empire of Napoleon III.

Segmental Arch

An arch where the head is less than a full half circle, but is only a segment of a circle. Historically, segmental arches are most often found in Georgian style, Italianate style, Spanish colonial and Federal style architecture.

Segmental Dormer

A dormer with an arched roof. The name is derived from the dormers roof being a segment of a circle.

Segmental Pediment

A pediment above a roof or window which has a rounded top, in other words, a segment of a circle. Also known as a curved pediment.

Semicircular Arch

An arch with a semicircular head.

Semicircular Fanlight

A fanlight, semicircular in shape, usually over the main entry door.

Semicircular Window

A window with a semicircular head or a window having the shape of a semicircle.

Simielliptical Arch

An arch in the shape of half of an ellipse.

Sexfoil

In tracery, a window or foil with six cusps. From the French word "foil" meaning "leaf". A leaf-shaped curve or lobe, formed between points called cusps inside an arch or circle. Used in Gothic style tracery windows. Also in fountain pools having the sexfoil shape in plan.

Shell-headed

An architectural element that resembles half a scallop shell, used as the head of a niche, or as a decorative element.

Sill Course

A banding that wraps a building horizontally at the height of the window sills.

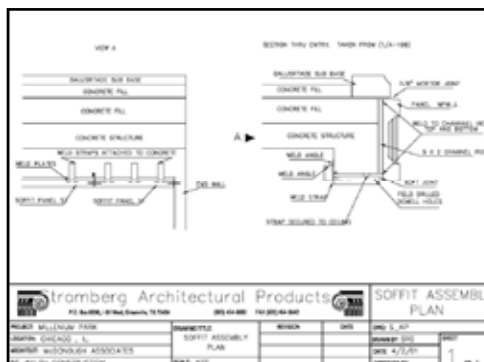
**Soffit**

The underside of any architectural component that is overhead, including the exposed underside of a beam, arch, balcony, lintel or cornice.

Spandrel

1. In modern high-rise construction, the wall panel located between the top of one window at one story and the bottom of the window above it at the next story. Can be made of GFRC, architectural fiberglass, stone, metal, or glass. 2. The triangular shaped area between two arches or between an arch and a wall.

Spanish Colonial Architecture (American)

The architectural style of the Spanish missions, and settlements of the American Southwest. Also known as Mission Architecture. Common architectural elements include columns, domes, canales (water spouts through the roof parapet,) vigas, carved rafter tails and low relief carved door surrounds and window surrounds. Other features sometimes used are decorative cornices and corbels and columns and pilasters along a long covered portale (porch) or arcade, balconies and loggias.

Spiral Stair

A stairway with approximately wedge-shaped treads, circular in plan. Also known as a helical stair, circular stair or caracole.

Spire

Any tall slender pointed roof element. Spires or steeples may be architectural fiberglass or GFRC. Spires are generally of one piece construction or made in segments for bolting to the structure. The architectural fiberglass or GFRC skin wraps a steel framework.

**Splayed Lintel**

A lintel with a top dimension larger than the bottom dimension, so that each end slants upwards away from the center line of the window.

Springer

Also known as the springing point is the place where the arch begins and where the curved arch rests on the vertical support below. The Springer is also the term for the first or lowest voussoirs or stones of an arch.

Stair Bracket

The decorative detail at the end of each step in a stairway.

Standing Seam

A raised rib at roofing panels or dome Segments.

Steeple

A tall slender structure, generally above a church tower or a cupola. Usually topped by a small spire or cross. Steeples may be GFRP (architectural fiberglass) or GFRC.

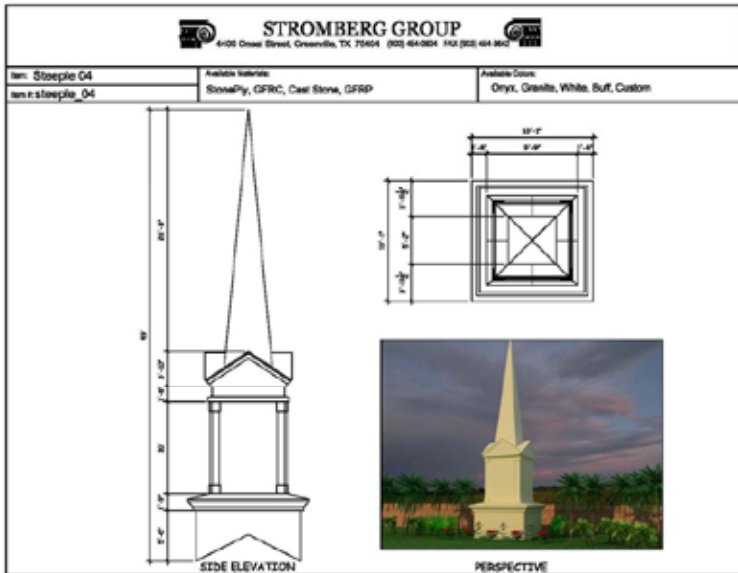

Design of a architectural fiberglass (GFRP) or (GFRC) steeple

Stepped Arch

An arch with voussoirs (stones) cut horizontally or vertically so that they line up with the masonry courses.

Stepped Gable

A gable with the stepped edge.

Sullivan-esque

The term used to describe architectural style and decorative designs created by Louis H. Sullivan, the American architect.

Sun Disk

The Egyptian emblem of the sun, a disk with wings. Sometimes used as a decorative element or window head in Egyptian revival architecture.

Supercolumniation

Also known as superposition, refers to the placing of one order of classical columns above another. For example Doric columns at the first floor and Ionic at the second floor directly above them.

Surround

Frame or decorative element around a doorway, a window or a fireplace. See door surround, fireplace surround or window surround.

Swag

A decorative element representing a garland of ribbons, draped fabric, flowers or fruit, appearing to be tied at the end and draping down in the middle.

Swan's-neck Pediment

A pediment with a sloping S-shaped element on either side. The name comes from the S-shaped pediment tops that are somewhat similar to the necks two swans facing each other.

Terra-Cotta

Architectural terra-cotta is a Clay which is been molded and shape, fired in a kiln and glazed. Terra-cotta was used as a facing on buildings in America mostly from around 1860 until the 1930s. In historic restorations, because of difficulties in replacing terra-cotta, color matching and durability issues, GFRC (glass fiber reinforced concrete) or FRP (fiber reinforced polymer) is often used as the terra-cotta replacement. Stromberg produces a special glazed GFRC and a fiberglass (FRP) which closely resembles glazed terra-cotta. Custom color matching is available, and new GFRC elements can be created with molds taken from existing terra-cotta, or from historic drawings and photographs if the terra-cotta no longer exists.



Tongue-and-art Molding

A decorative molding that features alternating tongue like shapes and dart like shapes. Similar to egg and dart.

Torus

A projecting, convex molding, which forms the “ring” at the base of a column. Architectural columns of the Corinthian and Ionic order typically have the “Attic” style base with two rings. The Tuscan column base has a single torus.



Torus on a Tuscan style column base in Coral Stone texture Available in GFRC, GRG or architectural fiberglass (GFRP)

Tower

A tall, horizontal structure or building.

Tracery

Lace like shapes, most often found in Gothic architecture, that create a pattern in windows and other openings.



Stromberg Architectural Fiberglass tracery being installed

Trefoil

A three lobed pattern in a foil. From the French word “foil” meaning “leaf”. A leaf-shaped curve or lobe, formed between points called cusps inside an arch or circle. Used in Gothic style tracery windows.

Trefoil Arch

A pointed arch with three centers.



Trefoil arch in architectural fiberglass

Trellis

An open lattice or grate for the support of vines and other climbing plants.

Triangular Arch

A simple arch with no curves, created by two diagonal elements meeting at a point.

Triangular Dormer

A dormer with a triangular roof.

Triglyph

A Doric frieze ornament, consisting of a rectangular block with two V shaped grooves and two half V grooves on either edge. Triglyphs alternate with sculptured or plain blocks called metopes. Used in Greek architecture and the Greek Revival style.

Trim

The framing or edging of openings and other features on a building, including window surrounds, cornices, base moldings and casings.

Turret

A cylindrical tower, often corbelled on the corner of a larger structure. Usually with a conical roof.

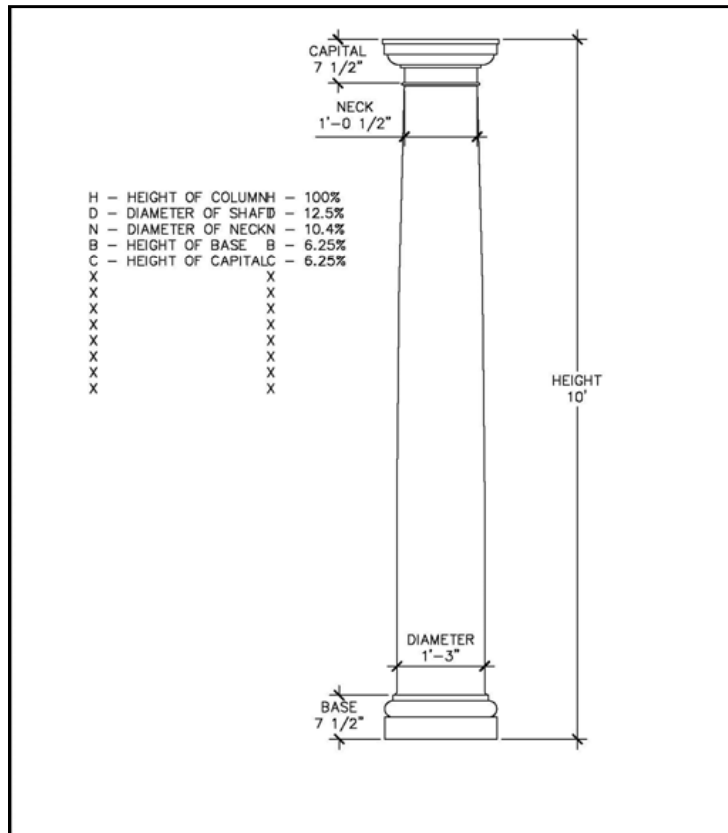
**Tuscan Order**

The Tuscan Order was the simplest of the Classical Orders. It developed from Etruscan and early Roman temples. The column capitals and bases are simpler than those of the other orders and the shaft is not fluted. Palladio recommended that its plainness made it suitable for use in buildings of utilitarian function.

Tuscan Villa Style

A style derived from the villas of Tuscany, similar to the Italionate style, but symmetrical in plan.

Tympanum

The triangular space in a pediment. Enclosed by the horizontal cornice, and the sloping, diagonal sides. The tympanum may be plain, or may feature a decorative element, window, or other embellishment.

Vault

A structure composed of an arrangement of arches that form a covering over a space.

Veneer

A facing of brick, cast stone, GFRC, Architectural Fiberglass or other material that forms a durable, decorative surface over a structure, but is not load bearing itself.

Vermiculated Work

From the Latin for worm, Vermiculated surfaces have a series of wavy, disconnected grooves that resemble worms or the tracks of worms.

V-joint

A joint in mortar or sealant with a V shaped groove.

Volute

A spiral shape, as on an Ionic column capital. From the Latin Volutus for turned. Volutes are also used on the capitals of the Corinthian and Composite column.



Voussoir

The term for one of the blocks or units that make up an arch. The top voussoir is the keystone. The lowest voussoir is the springer.



GFRG Voussoir arch

Wainscot

The covering for the lower part of a wall.

Wheel Window

Circular window divided by tracery similar to the spokes of a wheel. Generally found in churches and in Gothic architecture and its derivatives.

Window Crown

The upper part of a window such as a pediment or hood.

Window Surround

The molding that surrounds a window.

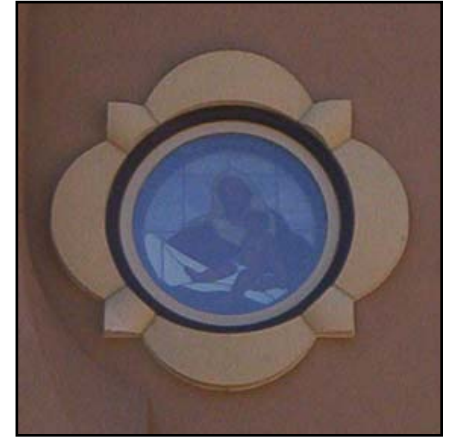
**DISCLAIMER FOR USE:**

We have published this Architectural glossary as a service to you, and the other architects, designers, owners and contractors like you, who have become our clients and friends over the past 20 years. I hope you find them useful. If you don't see what you need here, contact us and we will be happy to help you. If you use our drawings, details or specifications, we would appreciate your including us as an approved supplier on your project.

PERMITTED USES:

This glossary, unless used by an Architect or Designer, may be used only for the purpose of developing plans; specifications and/or approval drawings for construction projects utilizing products manufactured or distributed by Stromberg Architectural Products Inc.

NON-PERMITTED USES:

Without the express written consent of Stromberg Architectural Products, Inc. you may not use the Photos for any purpose other than the permitted uses described above.

WARRANTY:

Stromberg Architectural Products, Inc. its employees, suppliers and agents, make **NO WARRANTY OR REPRESENTATION** regarding the quality, content, form, performance, fitness for purpose, merchantability or otherwise, regarding this glossary. You utilize this glossary at **YOUR OWN RISK** and Stromberg has and shall have no responsibility for your utilization of this glossary.

LIMITATION OF LIABILITY:

Stromberg has **NO LIABILITY**, express or implied, to you or any third party arising out of your utilization of this glossary for any and all purposes. In the event that it is determined that Stromberg does have any

liability, of whatever nature, the liability is **LIMITED** to compensatory damages of a maximum amount not to exceed \$500.00 and there shall be no liability for consequential or punitive damages.

NOTICE:

Descriptions and specifications contained herein were in effect at the time this publication was approved. In a continuing effort to refine and improve products, Stromberg reserves the right to discontinue products at any time or change specifications and/or designs without incurring any liability or obligation. Application details are for illustration purposes only, and may not be appropriate for all environmental conditions, building designs, or panel profiles. Projects should be engineered to conform to applicable building codes, regulations, and accepted industry practices.