

FRONT VIEW

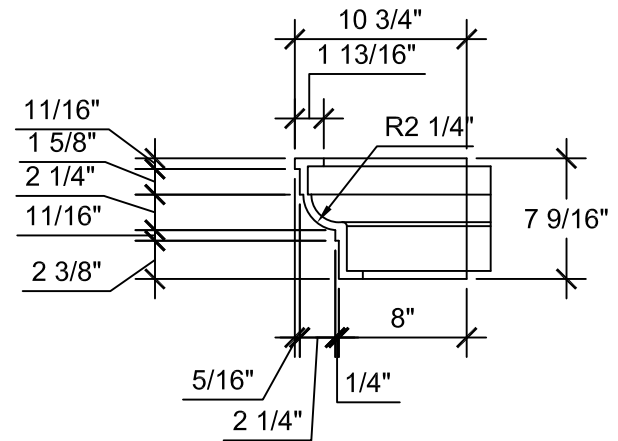

SECTION A

ALL RIGHTS RESERVED. THIS DRAWING IS PROPERTY OF STROMBERG ARCHITECTURAL PRODUCTS INC. AND MAY BE USED ONLY WHEN UTILIZING STROMBERG ARCHITECTURAL PRODUCTS. STROMBERG ARCHITECTURAL PRODUCTS INC. GENERAL TERMS AND CONDITIONS APPLY AND ARE INCORPORATE HERE IN BY REFERENCE. THIS DETAIL MAY NOT APPLY TO ALL CONDITIONS AND CONSTRUCTION SITUATIONS.



STROMBERG ARCHITECTURAL PRODUCTS INC.

4400 Oneal Street, Greenville, TX 75401 Phone 903.454.0904 Fax 903.454.3642

TITLE: CLARK ATLANTA UNV

TYPE DWG: COLUMN CAPITAL

SCALE: AS NOTED

DWG. SHEET: **CLARK ATLANTA CC**