

WINDOW SURROUND REQUIREMENT		
TYPE	OPENING	ELEVATION
37	LOWER LEVEL	NORTH
TOTAL SURROUND TYPE 37		1

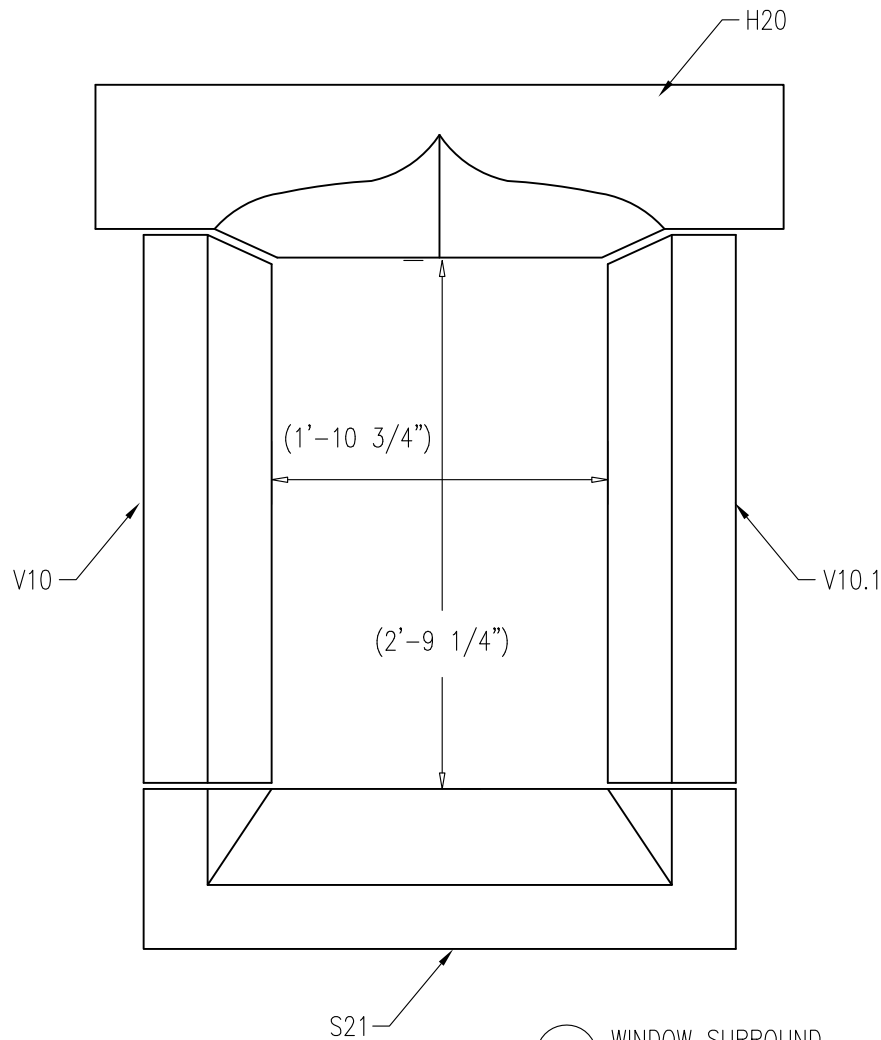

37 WINDOW SURROUND  
1" = 1'

PART LIST		
ITEM	DWG.	QTY.REQUIRED
H20	F17	1
V10	F18	1
V10.1	F18	1
S21	F19	1

ALL RIGHTS RESERVED. THIS DRAWING IS PROPERTY OF STROMBERG ARCHITECTURAL PRODUCTS INC. AND MAY BE USED ONLY WHEN UTILIZING STROMBERG ARCHITECTURAL PRODUCTS. STROMBERG ARCHITECTURAL PRODUCTS INC. GENERAL TERMS AND CONDITIONS APPLY AND ARE INCORPORATE HERE IN BY REFERENCE. THIS DETAIL MAY NOT APPLY TO ALL CONDITIONS AND CONSTRUCTION SITUATIONS.



STROMBERG ARCHITECTURAL PRODUCTS INC.

4400 Oneal Street, Greenville, TX 75401 Phone 903.454.0904 Fax 903.454.3642

TITLE: LITTLE PINE LAKE

SCALE: AS NOTED

TYPE DWG: WINDOW SURROUND 7

DWG. SHEET: **PINE WS7**